

---

# **BISOMAC308**

**Specifications for Latin America**

## **Electric Traction Hoist Operator's Manual**

---

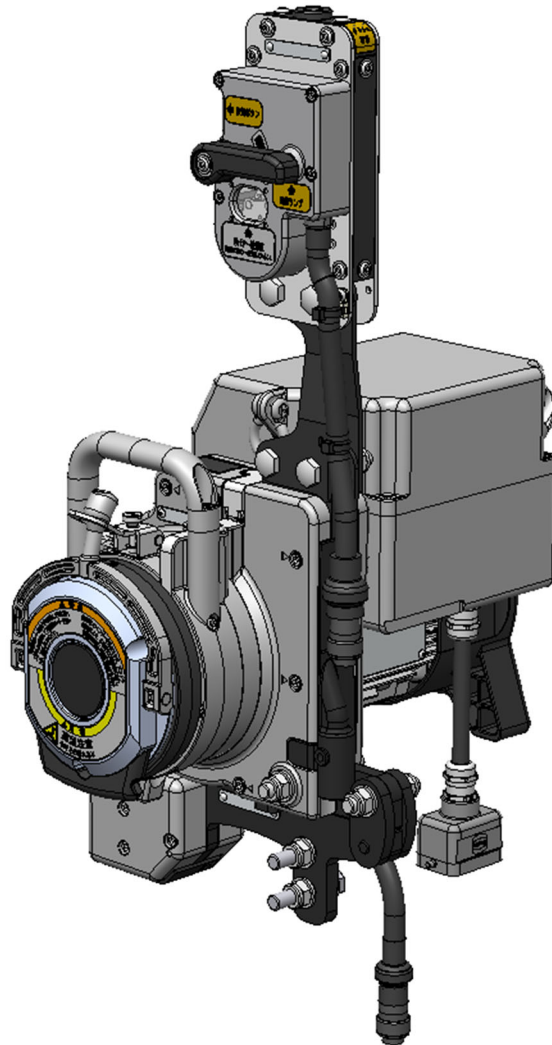

**NIHON BISOH CO., LTD.**

## IMPORTANT SAFETY INSTRUCTIONS

READ ALL INSTRUCTIONS BEFORE USING THIS EQUIPMENT.

Any operation in violation of these instructions may result in bodily injury or death.

### **WARNING**

- + All operators operating BISOMAC308 Electric Traction Hoist (hereinafter referred to as the hoist) must read and completely understand this manual.
- + All operators must be thoroughly trained and certified in the use of the hoist, its operational and safety features.
- + Only authorized and physically fit operators shall operate the equipment.
- + At the start of each work shift, daily test must be performed to ensure correct operation.
- + Any operations in violation of these instructions is operator's own risk and may result in serious injuries.
- + Keep this manual with the hoist at all time.
- + Use only spare parts and steel wire rope recommended by NIHON BISOH.
- + Use only machinery or incorporated component, which has been declared to be in conformity with designated standards for suspended platforms and national, regional, or local implementing.
- + It is the responsibility of the user of this hoist to determine that this hoist is suitable to be used in conjunction with any other equipment. The user must also determine that this hoist and other components used will be in strict conformity with the provisions of Federal, State, National and local ordinances and regulations.

**Manufacturer: NIHON BISOH CO., LTD.**

## TABLE OF CONTENTS

<b>0. READ BEFORE USE</b> .....	1
<b>1. FOR SAFE USE</b> .....	6
1.1 General.....	6
1.2 Maintenance.....	7
1.3 Hazard Symbols.....	7
<b>2. SPECIFICATION</b> .....	12
2.1 BISOMAC.....	12
2.2 BISOLOCK .....	12
2.3 BISOLOAD.....	13
2.4 Wire Rope.....	13
2.5 Power Cable.....	13
<b>3. FUNCTION AND DESCRIPTION OF EACH COMPONENT</b> .....	14
3.1 Hoist.....	14
3.2 BISOLOCK.....	18
3.3 BISOLOAD.....	19
<b>4. WORK ENVIRONMENT</b> .....	20
<b>5. SET UP INSTRUCTIONS</b> .....	21
STEP 1 Installation of safety devices to BISOMAC.....	23
STEP 2 Connecting to power supply.....	24
STEP 3 Installation of suspension wire rope.....	25
STEP 4 Installation of the hoist.....	26
STEP 5 Perform daily inspection.....	26
<b>6. OPERATING THE HOIST</b> .....	27
6.1 Carrying the Hoist.....	30
6.2 Operation method of the Hoist.....	30
6.2.1 Lifting and Emergency Stop.....	30
6.2.2 Emergency controlled descent lever.....	31
6.2.3 Releasing procedure of BISOLOCK.....	32
<b>7. DAILY TESTS AND INSPECTIONS</b> .....	33
7.1 Tests and Inspections: Rigging materials.....	33

7.2 Tests and Inspections: Wire rope.....	34
7.2.1 Shape and size of wire rope.....	34
7.2.2 Shape and size of the end of wire rope.....	35
7.3 Tests and Inspections: Hoist.....	36
7.3.1 Lifting the platform and emergency stop function.....	37
7.3.2 Controlled descent function.....	38
7.3.3 BISOLOCK.....	39
<b>8. PERIODIC MAINTENANCE.....</b>	<b>40</b>
<b>9. TROUBLESHOOTING AT JOB SITE.....</b>	<b>41</b>

**[Attachment]**

Wiring diagram of BISOMAC308 3P-608MX

## 0. READ BEFORE USE

This Operator's Manual is written for operators to use the Hoist safely and properly. To fully understand the usage of the Hoist, please refer to the following instructions and system compositions. (See Picture-1) It is responsibility of the user of the Hoist to determine whether the Hoist is safe according to this manual. Any operations in violation of the instructions in this manual is operator's own risk.

### [System configuration of the hoist and other applications]

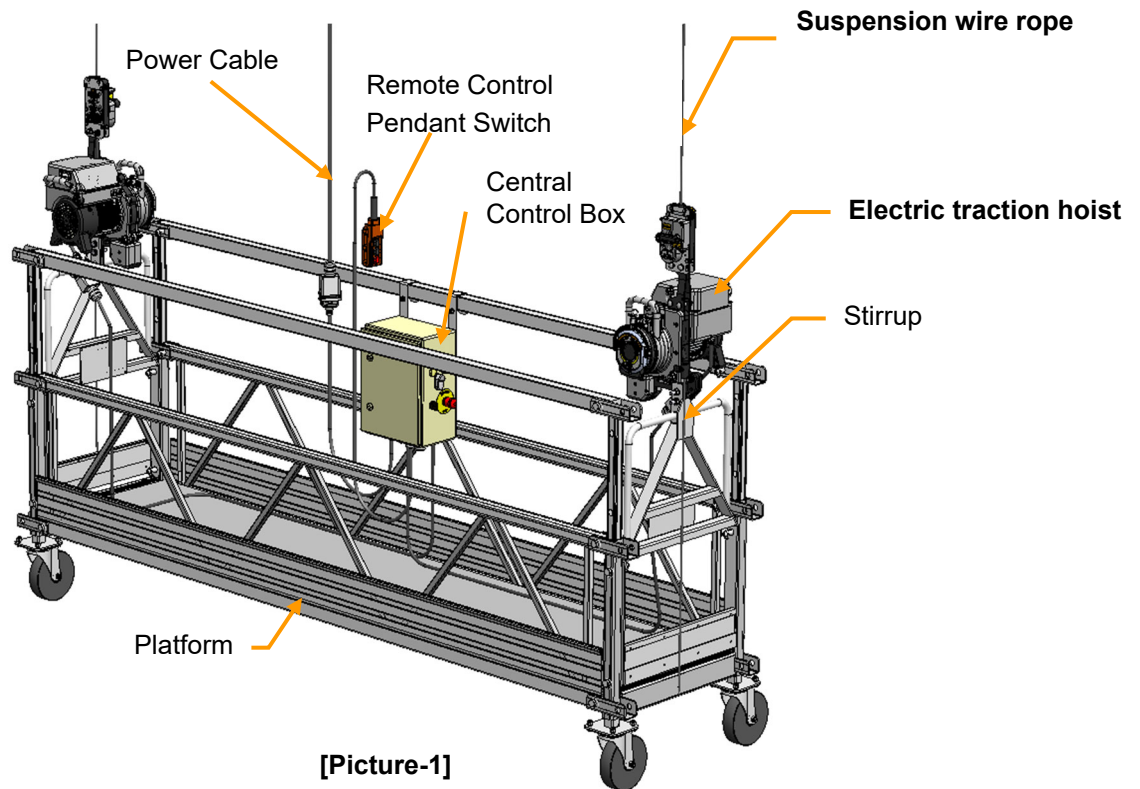

[Picture-1]

### (1) POWER SUPPLY TO THE HOIST MUST BE EQUIPPED WITH;

- a) Main switch

NOTE: Main switch or junction box shall have key-lock.

- b) Residual current device (or ground fault circuit interrupter) of 30 mA

- c) Overcurrent protective device (Automatic circuit breaker type C)

NOTE: To avoid voltage drop due to cable length, make sure that the specifications of power cable matches the requirement of the platform.

### (2) USAGE ENVIRONMENT

Temperature range: between  $-10^{\circ}\text{C}$  and  $+40^{\circ}\text{C}$

Humidity: 100% or less (without inundation, condensation and freezing)

Protection grade: IP54

Maximum wind speed: In accordance with the specification of platform

Altitude: 1,000 meters or lower

### **(3) CAUTIONS BEFORE USING**

- a) Before using the hoist, operators must perform the daily test to ensure correct operation.
- b) Before using the hoist, operators must confirm that there are no obstacles along the movement of platform.
- c) Before using the hoist, suspension system must be checked to ensure that platform is stable at all times.
- d) In case the area below platform is open to the public, preventive measures have to be taken to safeguard the people below (Ex. Barriers, roof protected walk ways, etc.).
- e) All hazards related to platform encountering obstruction are not completely covered by platform's safety devices. Operators shall check for obstructions along the travel of platform.
- f) Overload Detection Device may not cover platform in all configurations. Operators must check that loading of platform is according to the rated load displayed on the hoist.
- g) An area on the platform must be available to allow operators to operate the hoist safely.
- h) Use only certified safety harness, lanyard, rope grabs, and independent life lines at all times.
- i) In the cold weather, lifting operation of the hoist may not be available smoothly. Also, the hoist may not descend even emergency controlled descent lever is operated. Preventive measure not the hoist to be cooled must be taken.
- j) If the load on the platform is light, descent speed of emergency controlled descent may be slower. And if the load is lighter than the minimum load instructed in 2.1, the platform may not be lowered with the operation of emergency controlled descent lever.
- k) The suspension wire rope must be vertically set and installed to the hoist.

[Installation of the hoist 1]

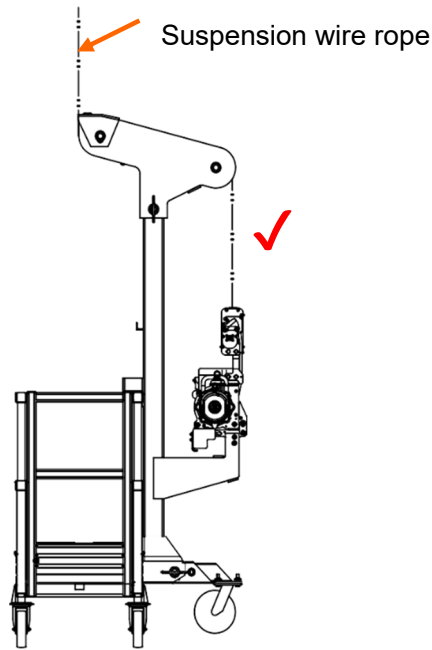

**Correct Installation**

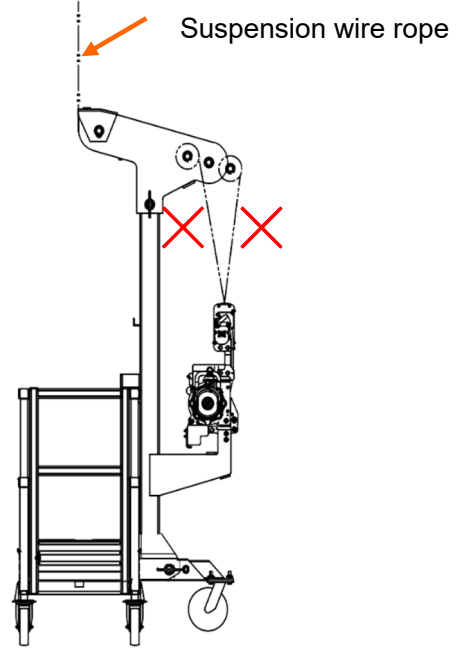

**NOT vertically suspended**

[Installation of the hoist 2]

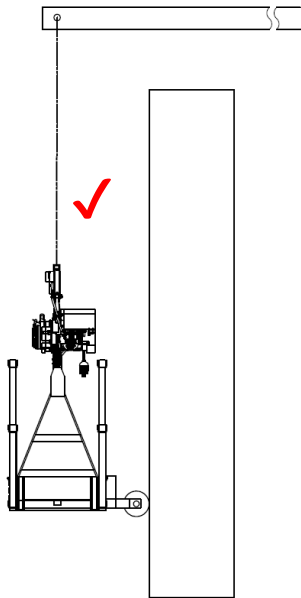

**Correct Installation**

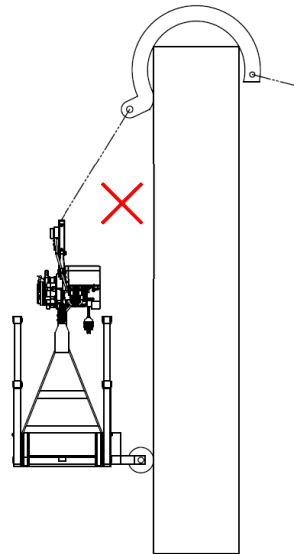

**NOT vertically suspended**

[Installation of the hoist 3]

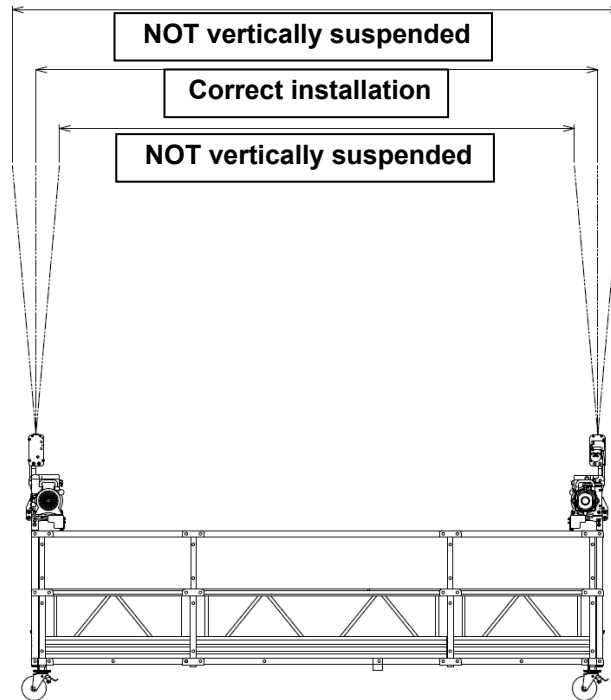

#### (4) CAUTIONS WHEN USING

- a) Stop operating and notify supervisor if any faults which may damage to safety of the hoist is found.
- b) Having suitable communication means between operators and supervisor is recommended.
- c) When not in use, unplug power cable and lock the equipment to protect from unauthorized use.
- d) If the hoist isn't operated for more than 30 minutes in the cold weather, ascending operation may not be operated smoothly. In that case, idle the hoist 30 seconds or operate descending operation before ascending.

#### (5) PROHIBITIONS

- a) The hoist is used only to raise, support and lower platform. Do not use for any other purpose.
- b) Do not use two or more units of the hoist with one wire rope.
- c) Do not insert wire rope from the wire rope outlet of the hoist.
- d) Do not tie and secure the discharged suspension wire rope from the wire rope outlet.
- e) Do not apply 20 kg or more pulling load to the discharged suspension wire rope from the wire rope outlet.
- f) Do not use the hoist as a material lifting equipment.
- g) Do not use the hoist in the water.
- h) Do not use the hoist as a hoisting device for elevator which permanently installed.
- i) Do not use the hoist as a traction device which pull horizontally.
- j) Do not use the hoist as a medical traction device.
- k) Do not use the hoist in potentially explosive atmosphere.



## **(6) STORAGE PROCEDURE**

Products shall be stored in accordance with the following conditions.

- a) The products and safety devices shall be stored indoor. In case necessarily store the products outdoor, only as a temporary storing, cover the products by waterproof sheeting or the like to prevent to be exposed to the direct sunlight and rain. Storage place shall be well ventilated not to become hot and humid, and avoid the products to be exposed to dusts, metal powders, and corrosive gas.
- b) Do not place the products directly to the ground but on the shelf or the pallets.
- c) Place the products as the wire rope inlet faces upward.
- d) If the products have been stored longer than 1 year, change the oil in the gear box and perform pre-shipment inspection according to the Maintenance Procedure Manual.
- e) If the products are to be stored longer than 3 months after use, operate without load a few minutes once every 3 months. When start using again, inspect the products if the electromagnetic brake works normally, and ensure that there is no abnormal noise, vibration, heating.

## **(7) WARRANTY EXEMPTION CONDITIONS**

The warranty shall be null and void in the following cases even within the warranty period.

- a) Any defect caused by the installation of the product or failure of connection with any other equipment.
- b) Any defect caused by failure in storing as determined in the Operator's Manual.
- c) Normal wear, tear, deterioration, corrosion, and consumable items.
- d) Any defect caused by the improper condition, environment and treatment, and abuse or failure to follow the manufacturer's recommended operation determined in the Maintenance Procedure Manual, Operator's Manual, and any other documentation which issued by the manufacturer.
- e) Corrosion of the exterior.
- f) Any defect caused by the inclusion of water, oil, metal piece, or any other foreign materials.
- g) Any defect caused by negligence, accident, modification, misuse, unauthorized repair, and exploitation.
- h) Any defect caused by fall or the damage in transportation.
- i) Any defect caused by the earthquake, fire, wind, flood, salt damage, smoke damage, gas, thunderbolt, abnormal voltage, and any other natural disaster, hazard or irresistible force.
- j) Any defect of the products which the serial number is modified.
- k) Any defect of the products or parts which supplied by other than the authorized dealer of BISOMAC.
- l) Any defect caused by the use or installation of parts which supplied by other than the authorized dealer of BISOMAC.

# 1. FOR SAFE USE

## 1.1 General

This Operator's Manual (referred to as this manual) is written for operators to use the hoist safely and properly. The hoist consists of Hoisting Device (referred to as BISOMAC), Fall Arrest Device (referred to as BISOLOCK), Overload Detection Device (referred to as BISOLOAD).

Electric Traction Hoist consists of:

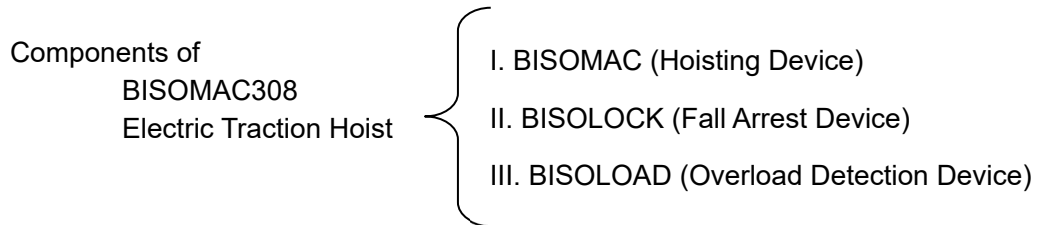

NOTE: The word "Safety devices" in this manual indicates BISOLOCK and BISOLOAD. For the specification of each device, refer to "2. SPECIFICATIONS".



1. Read and fully understand this manual before using the hoist.
2. The hoist is designed to be used to raise, support and lower platform.
3. Operating, handling, maintenance, inspection, and repairing of the hoist must be performed only by trained and certified operators.
4. Daily test and inspection must be performed at the start of each work shift according to "7. DAILY TEST AND INSPECTION".
5. Troubleshooting shall be done if any problem which possibly caused by the hoist according to "9. TROUBLESHOOTING" to find the cause of problem and take corrective action.
6. The hoist is used to raise, support and lower suspended scaffolds, work cages and bosun chairs on, or in building(s) and structures. If used for any other purpose, you must take all necessary precautions to be sure that both design and operation are hazard free, and such use conforms with manufacturer's specifications.
7. This manual is not all inclusive. It is impossible to anticipate every possible way this equipment may be used, and all possible hazardous situations. It is very important that you determine for yourself whether the equipment is safe. You must understand the operating characteristic of the hoist. You must understand how the hoist will operate in your application. You must be certain not to put yourself or others in danger, or cause damage to property or other persons.

## 1.2 Maintenance

Maintenance, inspections and repairs of the hoist must be performed by trained and certified personnel according to Maintenance Procedure Manual of each device (separately issued).

## 1.3 Hazard Symbols

Safety instructions are classified according to risk levels as follows.

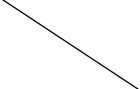
Symbol	Code Word	Meaning
	<b>WARNING</b>	Indicates a potentially hazardous situation which, if not avoided, could result in death or serious injury.
	<b>CAUTION</b>	Indicates a potentially hazardous situation which, if not avoided, may result in minor or moderate injury. It may also be used to show potential damage to property.
	<b>NOTE</b>	Indicates a potentially hazardous situation which, if not avoided, could result in damage of the BISOMAC.

Safety instructions attached to the hoist and safety devices

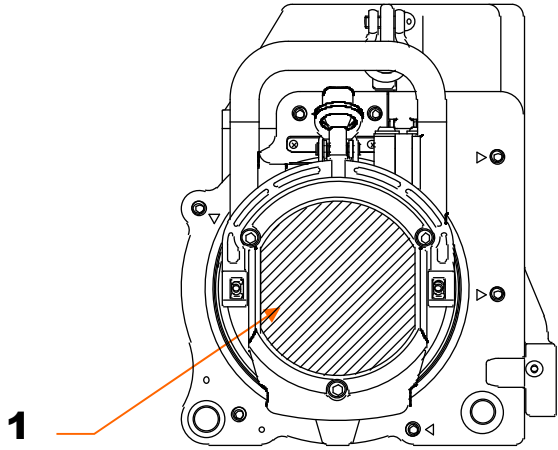
[BISOMAC FRONT SIDE]	
	
Description	Meaning and Location
<b>1. EMERGENCY DESCENT</b>	<ul style="list-style-type: none"> <li>• Instruction of Emergency Control Descent</li> <li>• Instruction of Electromagnetic Brake</li> <li>• Warning of burnt</li> </ul> <b>[ELECTROMAGNETIC BRAKE]</b>

**[BISOMAC UPPER SIDE]**

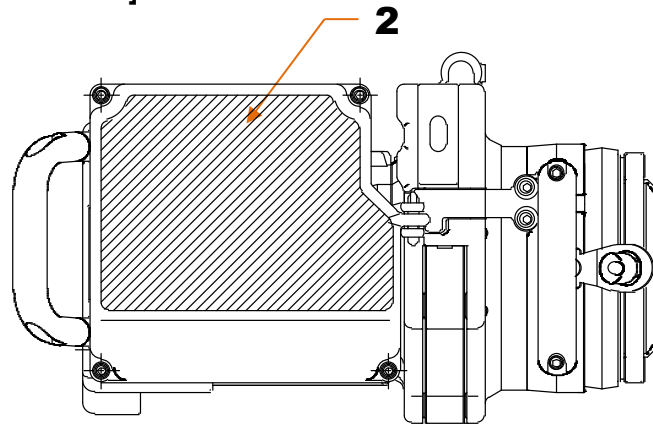

Description	Meaning and Location
<p><b>2. SPEC</b></p>	<ul style="list-style-type: none"> <li>• Instruction of specification and operation</li> <li>• With QR code to access operator's manual by electronic device</li> <li>• Instruction of shackle limit load</li> </ul> <p>[CONTROL BOX COVER]</p>

**[BISOMAC BACK SIDE]**

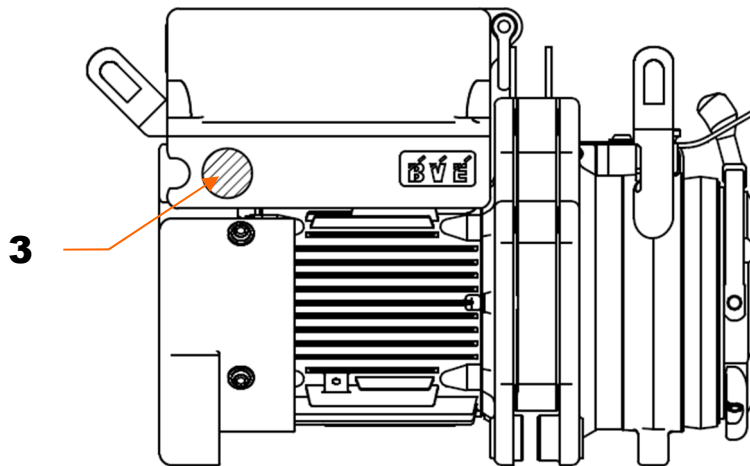

Description	Meaning and Location
<p><b>3. Manual Mark</b></p>	<ul style="list-style-type: none"> <li>• Showing the location of operation manual</li> </ul> <p>[CONTROL BOX]</p>

**[BISOLOCK FRONT/BACK SIDE]**

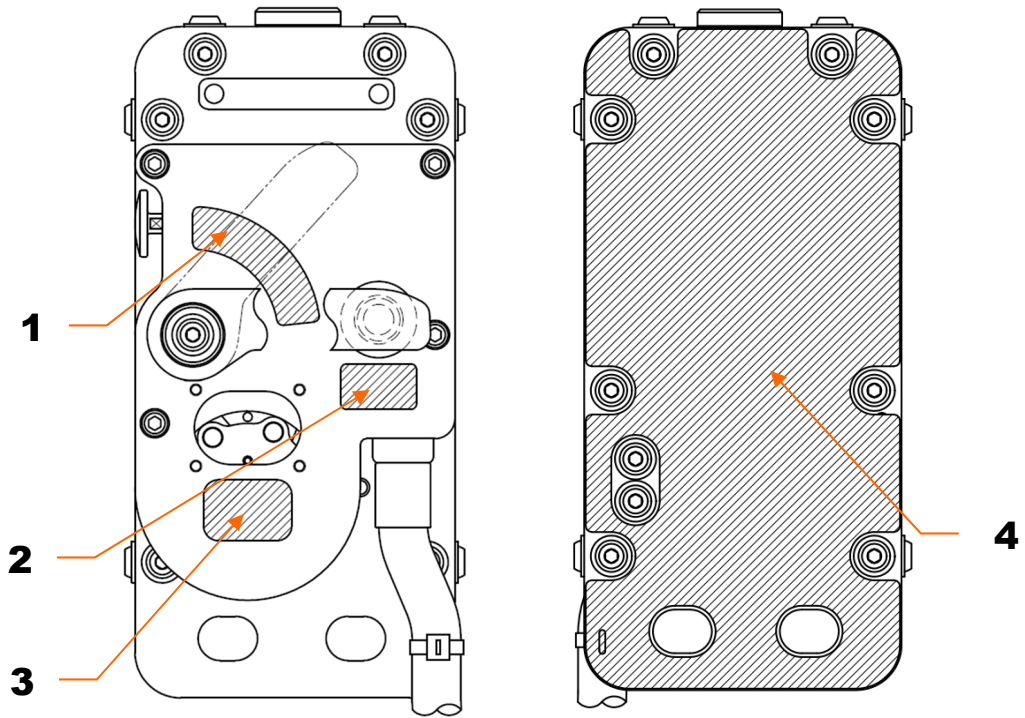

Description	Meaning and Location
<b>1. RESET</b>	<ul style="list-style-type: none"> <li>• Instruction of Reset Lever [GOVERNOR COVER]</li> </ul>
<b>2. OVERSPEED</b>	<ul style="list-style-type: none"> <li>• Instruction of Activation lamp [GOVERNOR COVER]</li> </ul>
<b>3. Governor Inspection Window</b>	<ul style="list-style-type: none"> <li>• Instruction of Governor [GOVERNOR COVER]</li> </ul>
<b>4. Instruction of OVERSPEED Detection Device</b>	<ul style="list-style-type: none"> <li>• Instruction of activation of the device</li> <li>• Instruction of spec and operation of the device [SIDE PLATE]</li> </ul>

**[BISOLOCK LEFT SIDE / TOP SIDE]**

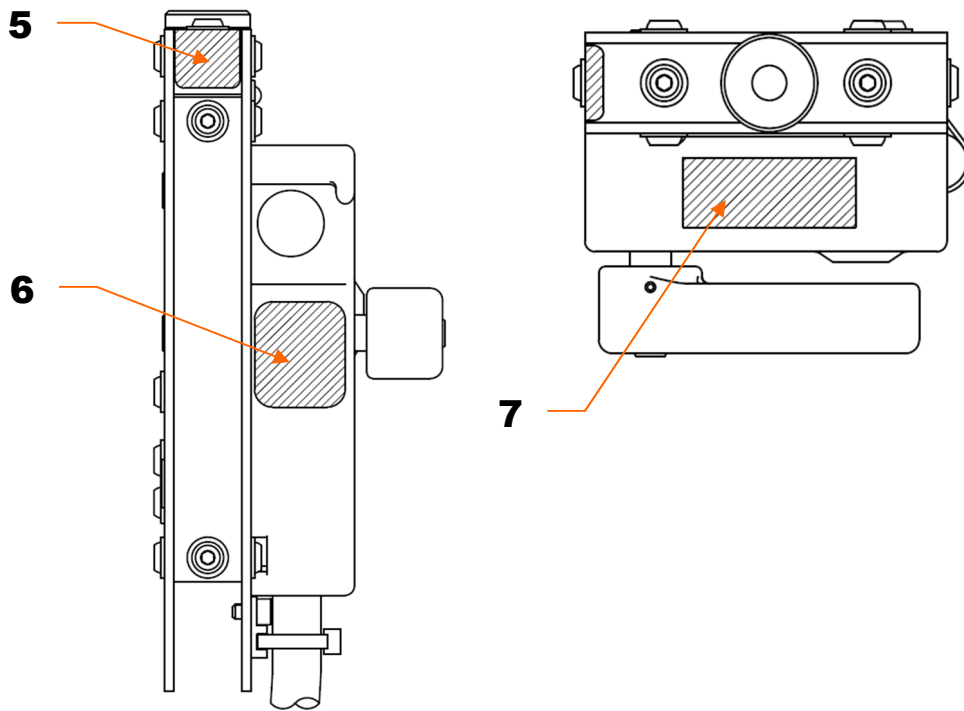

Description	Meaning and Location
<b>5. Wire Rope Diameter</b>	• Instruction of wire rope diameter [SIDE COVER 1]
<b>6. Instruction of Manual Trip Button</b>	• Instruction of Manual Trip Button [GOVERNOR COVER]
<b>7. Instruction of inability of lifting</b>	• Instruction of inability of lifting [GOVERNOR COVER]

[BISOLOAD LEFT SIDE]

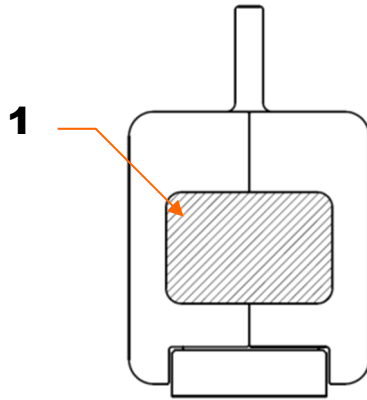

Description	Meaning and Location
1. Rated Load	• Instruction of rated load [LIMIT SWITCH COVER]

## 2. SPECIFICATIONS

### 2.1 BISOMAC

Model	Rated Load	Power Voltage	Ampere in Rated Load	Wire Rope Dia.	
				Nominal Diameter	Range
BISOMAC308 3P-608MX	600 kg	200/220 V 60 Hz	8.0 A	8 mm	8.0-8.4 mm

Power / Voltage	3Phase 200V/220V ±10% (60Hz)	
Motor Power	1.1 kW (4P)	
Rated Speed	12.0 m/min	
Controlled Descent	13.0 m/min or slower	
Minimum Load	150 kg	
Rated Operating Time	60 minutes	
Noise	68 dB NOTE: This value is measured at a position 1 m away from the hoist. Noise level may vary depending on the voltage or environment.	
Protection Construction	IP54	
Dimension (H × W × D) includes safety devices	690 mm x 299 mm x 445 mm	
BISOMAC Self Weight	37 kg	
Weight includes safety devices	43.8 kg [BISOLOCK: 3.0 kg, Mounting bracket: 0.8 kg, BISOLOAD 3.0 kg]	
Control Method	Central Control Method	
Safety Features	1. Electromagnetic brake 2. Descent speed control 3. Motor built-in thermal protector (Temperature detection type) 5. Fall arrest device (BISOLOCK) 6. Overload detection device (BISOLOAD)	
Work environment	Temperature	Between -10°C and +55°C
	Pressure	Standard atmospheric pressure
Maintenance Cycle	1 year or 100 operating hours since last maintenance. NOTE: It depends on the actual condition of use at work sites. (Refer to "4. WORK ENVIRONMENT".)	

### 2.2 BISOLOCK

Model	BISOLOCK308-SP608MX
Rated Load	600 kg
Activation Speed	30 m/min
Dimension (H × W × D)	226 mm x 93 mm x 105 mm
Weight	3 kg
Function	No descent while BISOLOCK SP is activated.
Use Voltage	200 V



### 2.3 BISOLOAD

Model	BISOLOAD308-600MX
Rated Load	600 kg
Activation Load	750 kg (600 kg x 125%)
Dimension (H x W x D)	132 mm x 78 mm x 299 mm
Weight	3 kg
Control Feature	Unable ascending when BISOLOAD is activated.
Use Voltage	200V

### 2.4 Wire Rope (Designated by NIHON BISOH)

No.	1	2	3
Diameter	8.3 mm	8.3 mm	8.2 mm
Construction	4 x 26	5 x 26	6 x 19
Min. Breaking Load (Actual)	44.9 kN (4,590 kg)	47.1 kN (4,806 kg)	50.5 kN (5,153 kg)
Treatment	Galvanized	Galvanized	Galvanized
NOTE	Designnated wire ropes by NIHON BISOH.		



### WARNING

#### Use only designated wire rope by manufacturer

Using any other wire rope may cause BISOMAC and BISOLOCK malfunction. It could result in serious injury or death due to falling or tilting of the platform.

### 2.5 Power Cable

**NOTE:** Due to the various possible suspended platform loading situations and power sources, it is impossible to specify the maximum length of the power cable exactly. When the hoist is difficult to start up, take measures against voltage drop such as boosting voltage and/or using thicker size of cable.

Recommended Type	2CT
Core and Size	4 cores 3.5 mm <sup>2</sup> minimum
Rated Voltage	600 V or less
Length	150 m or shorter per a platform

### 3. FUNCTION AND DESCRIPTION OF EACH COMPONENT

#### 3.1 Hoist

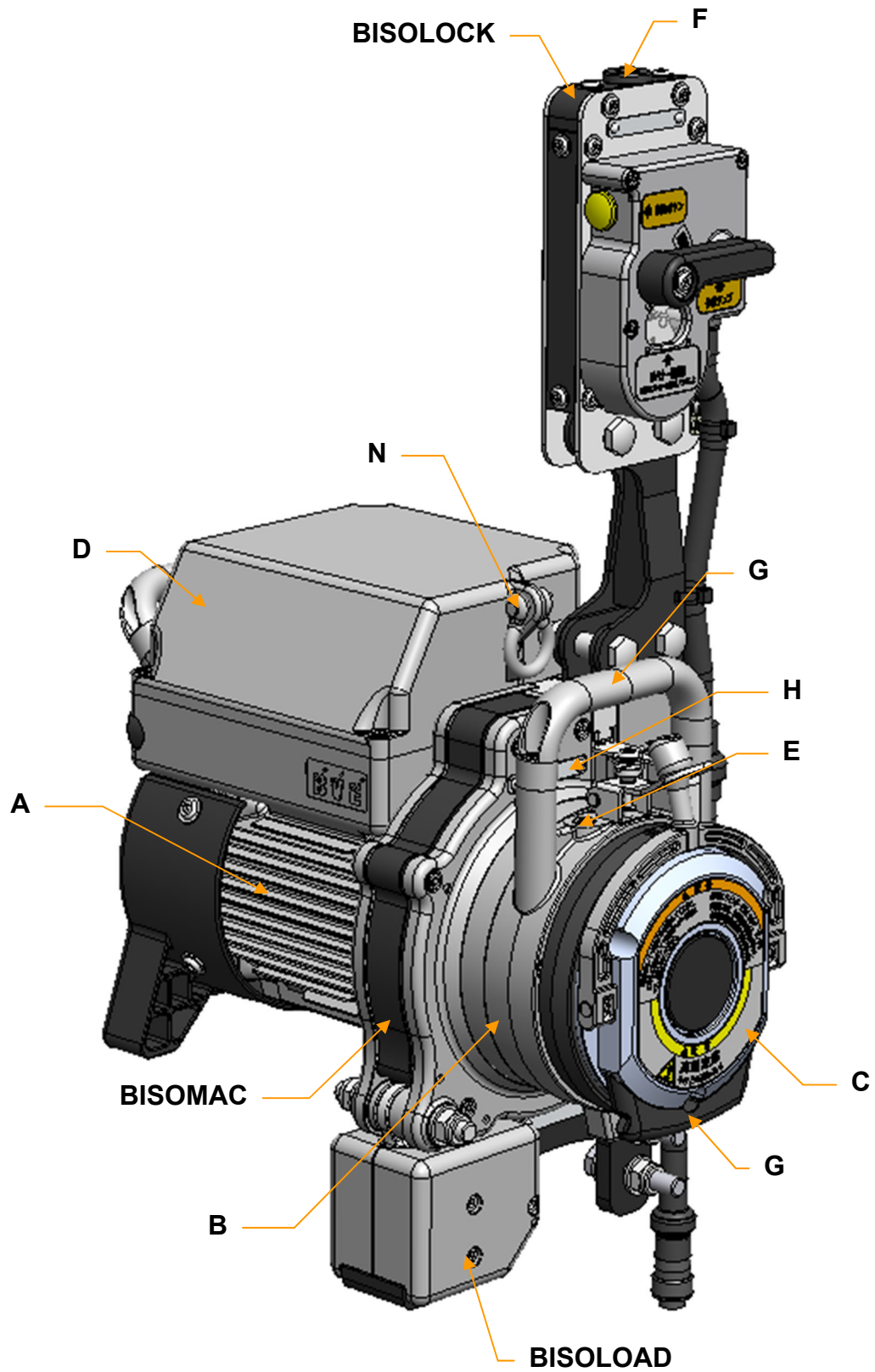

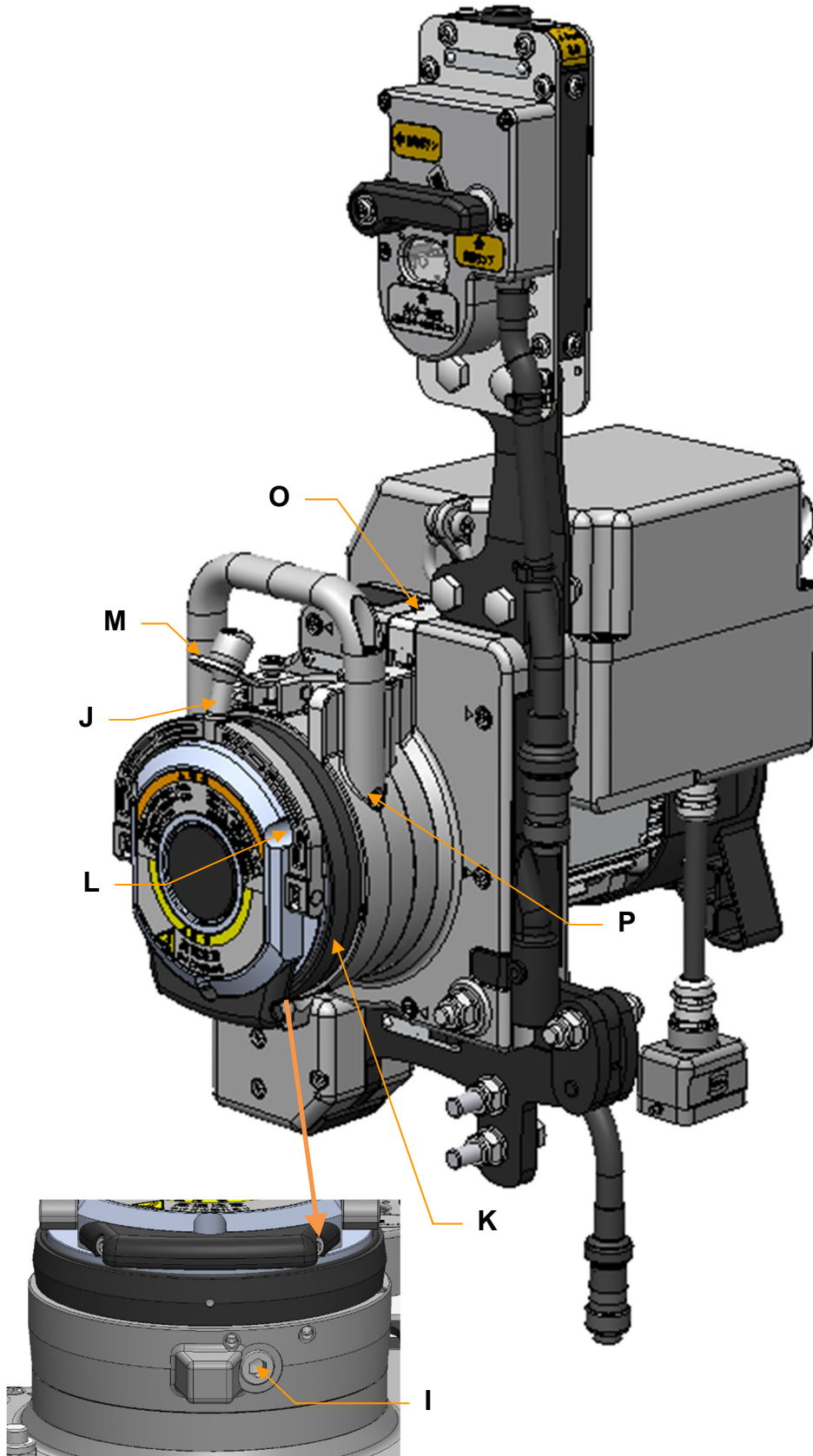

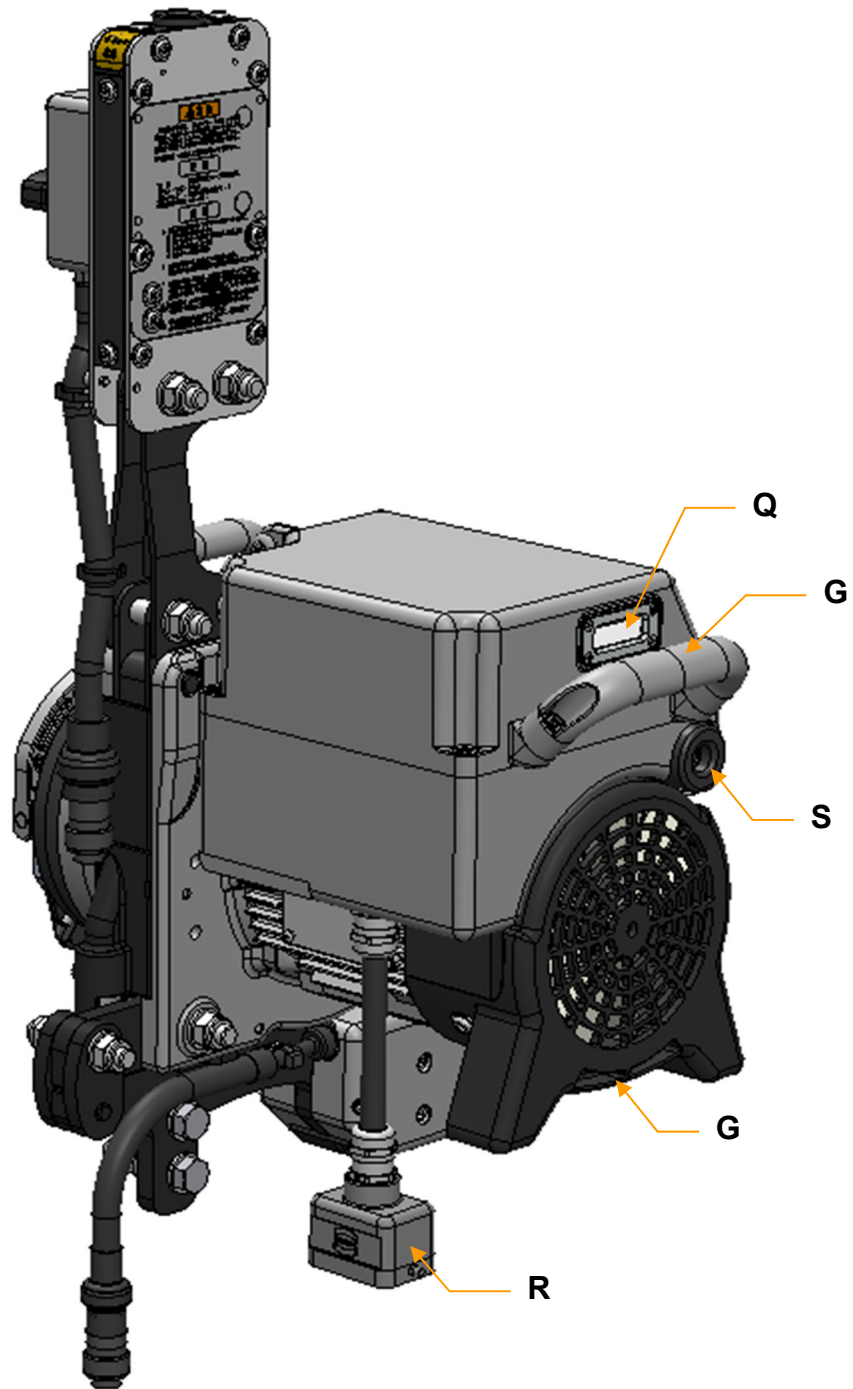

	FUNCTION	DESCRIPTION
<b>A</b>	Electric Motor	BISOMAC is driven by the motor with electricity.
<b>B</b>	Gear Box	Decelerate rotation speed of the motor to lift the rated load with rated speed.
<b>C</b>	Electromagnetic Brake	Released when the operation button is pressed. When the operation button is released or power is cut off, brake is activated and BISOMAC stops lifting.
<b>D</b>	Control Box	Electric components inside.
<b>E</b>	Oil Inlet	Open it when replacing oil.
<b>F</b>	Suspension Wire Rope Inlet	Inserting suspension wire rope from here.
<b>G</b>	Carrying Handles	Use when carrying BISOMAC.
<b>H</b>	Serial Number	Serial Number of BISOMAC.
<b>I</b>	Oil Outlet	Open it when discharging oil.
<b>J</b>	Emergency Controlled Descent Lever	It allows downward travel at a controlled speed without power.
<b>K</b>	Dust Cover	Protection cover not water and dirt to get into Electromagnetic Brake.
<b>L</b>	Water-proof Cap Bolt	Cap bolt with sealing to avoid water getting into Electromagnetic Brake.
<b>M</b>	Lever Stopper	Lock the lever automatically to prevent misoperation and malfunction of Emergency controlled descent lever.
<b>N</b>	Shackle	Use it when carrying BISOMAC by hanging. <b>NOTE:</b> Maximum lifting load is 50 kg.
<b>O</b>	Guard Plate for Brake Cable	Protect Brake cable from damage.
<b>P</b>	Oil Level Gauge Plug	Open it to check the oil level.
<b>Q</b>	Hour Meter	Displays accumulated operating hours.
<b>R</b>	AC Power Plug	Connect it to power source to supply power to BISOMAC.
<b>S</b>	Operator's Manual Cap	Operator's manual is stored inside.

### 3.2 BISOLOCK

BISOLOCK is fall arrest device which holds suspension wire rope when the platform suddenly fell. When BISOLOCK-SP is activated, lowering operation shall be locked electrically and Activation Indicator Lamp lights up if DOWN operation is operated. Only UP can be operated.



#### WARNING

**1. If the platform suddenly fell and BISOLOCK is activated, only trained and authorized personnel are allowed to release BISOLOCK.**

Contact local authorized distributor for rescue. Improper reset may cause the platform to fall or tilt and consequently operators or objects might fall, resulting in serious injury or death to operators or passers-by.

**2. If the platform continues descending even you released DOWN button or pressed Emergency Stop Switch, press Trip Button to activate BISOLOCK.**

Platform, operators, or objects might fall. It may result in serious injury or death to operators or passers-by.

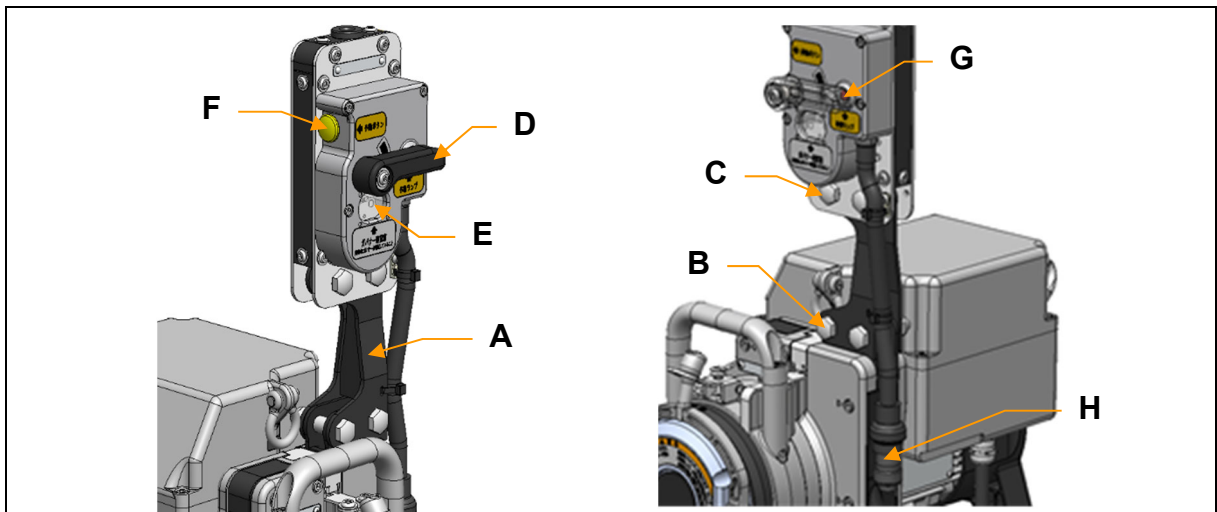

	DESCRIPTION	FUNCTION
<b>A</b>	BISOLOCK Mounting Bracket	Mounting bracket for fixing BISOLOCK to the Hoist.
<b>B</b>	Bolt for BISOLOCK Mounting Bracket	Bolts for fixing BISOLOCK Mounting Bracket to the Hoist.
<b>C</b>	BISOLOCK Mounting Bolt	Bolts for fixing BISOLOCK to the Hoist.
<b>D</b>	Release Lever	Lever for deactivating BISOLOCK. <b>NOTE:</b> DO NOT forcibly release BISOLOCK when it is activated due to strong impact load. Safety pin will be broken and unable deactivate BISOLOCK.
<b>E</b>	Governor Inspection Window	Window to check the rotation of governor.
<b>F</b>	Trip Button	Switch to activate BISOLOCK manually.
<b>G</b>	Activation Indicator Lamp	Lights up if DOWN button is pressed when BISOLOCK is activated.
<b>H</b>	Connector	Connects to the Central Control Box to transmit electric signals from BISOLOCK.

### 3.3 BISOLOAD

BISOLOAD is overload detection device. When BISOLOAD detects overload to the Hoist (125% of rated load), ascending operation shall be locked electrically.

#### **WARNING**

**If the Hoist does not ascend even UP button is pressed or pumps while ascending, unload from the platform.**

Otherwise the rigging may fall or tilt due to overloading and consequently operators or objects might fall, resulting in serious injury or death to operators or passers-by.

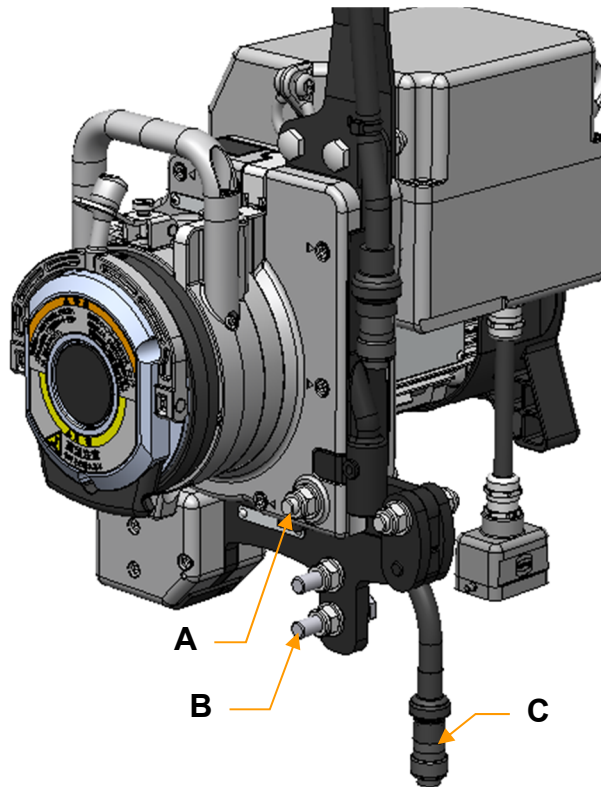

	FUNCTION	DESCRIPTION
<b>A</b>	BISOLOAD Mounting Bolt B	Bolts for fixing BISOLOAD to the Hoist.
<b>B</b>	Stirrup Fixing Bolts	Bolts for fixing BISOMAC to the platform.
<b>C</b>	Connector	Connects to the Central Control Box to transmit electric signals from BISOLOAD.

#### 4. WORK ENVIRONMENT

Many work environments where the Hoist is used contains contamination which may affect performance and operation of the Hoist. Inspect the operation of the Hoist frequently according to section 7.

When using the Hoist in a dirty environment that contains epoxy, paint, cement, sand blast residue, or corrosive material, protective covers are recommended.

Protective covers may hide safety instructions and warning labels. Before operating the Hoist, put off the covers and make sure to read all the labels and fully understand the instructions and warnings on the labels.

#### WARNING

**1. When using the Hoist in a dirty environment, inspect the operation of the Hoist frequently.**

**Perform disassemble maintenance after completing work at each work site to remove contamination in the Hoist and inspect the operation of the Hoist.**

Contamination in the Hoist may cause malfunction. This may cause the platform to fall or tilt and consequently operators or objects might fall, resulting in serious injury or death to operators or passers-by.

**2. Never operate the Hoist in an explosive atmosphere. The Hoist is not designed to be used in such environment.**

If the Hoist is used in an explosive atmosphere, explosion or fire may occur. This might result in serious accidents.

**NOTE:** An explosive atmosphere is defined as a mixture of dangerous substances with air, under atmospheric conditions, in the form of gases, vapors, mist or dust in which, after ignition has occurred, combustion spreads to the entire unburned mixture.

#### CAUTION

**Prolonged use of the Hoist with protective covers may cause overheating of motor.**

When using protective covers, check if the air supply to the motor is sufficient frequently, and if it's overheated, stop operating and wait for cooling down.

**NOTE:** When using the Hoist in a dirty environment that contains epoxy, paint, cement, sand blast residue, or corrosive material, performance and operation of the Hoist may be affected. Using protective covers are recommended.

**NOTE:** When using the Hoist in freezing temperatures, freezing of moistures in the Hoist may affect the operation of components of the Hoist. Oil in the gear box may be cured. This may cause BISOMAC to start hardly. After work, necessary preventive measure not to freeze moistures in the Hoist must be taken.



## 5. SET UP INSTRUCTIONS

This section describes necessary procedure for safe use of the Hoist.

Read and fully understand procedures described in steps 1-5 before setting up.

### [WARNING: INSTALLATION]

#### **WARNING**

**1. Do not allow anyone under suspended equipment.**

Objects might fall, resulting in serious injury or death to passers-by.

**2. Do not use different type of hoist in one platform.**

Otherwise, operation error may occur from the difference in the performance (lifting speed, etc.) and the difference of the operation method of hoists and the difference of safety devices. This may cause the platform to fall or tilt and consequently operators or objects might fall, resulting in serious injury or death to operators or passers-by.

**3. When attaching the hoist to the platform, make sure how to fix safety devices in advance.**

Otherwise, safety feature may not work properly. This may cause the operators or objects to fall, resulting in serious injury or death to operators or passers-by.

**4. Attach ground fault circuit interrupter to power source and ensure that it is properly grounded.**

Failure to do so, increases the risk of electric shock or electrocution resulting in death.

**5. Do not use power cable and control cable which damaged or cracked.**

Doing so could result in electrocution or death.

**6. Operators are not allowed to open central control box.**

Doing so could result in electrocution or death.

**7. When connecting safety devices to BISOMAC, make sure that the plug is completely dry and no moisture inside.**

Otherwise, malfunction may occur. This may cause the platform to fall or tilt and consequently operators or objects might fall, resulting in serious injury or death to operators or passers-by.

#### **CAUTION**

**Using protective cover is recommended for dirt prevention.**

Adhesion of foreign substances may cause the hoist inoperable.

### [CAUTION: CONNECTING POWER]

#### **CAUTION**

**The supply voltage to the hoist during operation should not exceed a range of  $\pm 10\%$  of the voltage instructed in Section 2.1.**

Otherwise motor may get overheated, result in malfunction or injury of operator. Rated voltage range ( $\pm 10\%$ ) is only temporarily acceptable. It does not mean continuously acceptable voltage range.

**[WARNING: SUSPENSION WIRE ROPE AND SECONDARY WIRE ROPE]**



**WARNING**

**1. Use only authorized wire rope. Strictly follow the method of use and instructions of manufacturer.**

Otherwise the hoist cannot achieve proper supporting strength or the rope may get birdcaged or broken. This may cause the platform to fall or tilt and consequently operators or objects might fall, resulting in serious injury or death to operators or passers-by.

**2. Do not expose the wire rope to fire, temperatures above 93°C, passage of electrical current, or corrosive atmospheres and chemicals.**

This exposure will make the rope unsafe and may cause the platform to fall or tilt and consequently operators or objects might fall, resulting in serious injury or death to operators or passers-by.

- Worn, kinked, birdcaged or damaged wire rope cannot be repaired. Must be replaced.
- When in doubt, replace wire rope.
- If wire rope is exposed to corrosive chemicals, do not save, replace it.

**3. The wire rope must be long enough to exceed the distance that platform will land on the ground or in place. (At least 2 m or more)**

Wire rope may get ran off from the platform. This may cause the platform to fall or tilt and consequently operators or objects might fall, resulting in serious injury or death to operators or passers-by.

**4. Do not operate the hoist with faulty wire rope such as kinked, deformed, tied, etc.**

Faulty wire rope may damage inside the hoist or wire rope may be broken. This may cause the platform to fall or tilt and consequently operators or objects might fall, resulting in serious injury or death to operators or passers-by.

**5. When fixing wire rope to a building, be sure that the wire rope does not contact any sharp edge.**

Otherwise, wire rope may be broken. This may cause the platform to fall or tilt and consequently operators or objects might fall, resulting in serious injury or death to operators or passers-by. Also broken wire rope may fall.

**6. Make sure that wire rope runs freely through the hoist.**

In consistent reeving speed suggests the wire rope or the hoist may be damaged. Stop operation immediately and replace the wire rope or the hoist. Otherwise, the wire rope may be broken or the hoist may stop. This may cause the platform to fall or tilt and consequently operators or objects might fall, resulting in serious injury or death to operators or passers-by.

**7. Do not secure or apply load to the end of suspension wire rope which exited from wire rope outlet.**

Parts inside the hoist may be worn down excessively and the wire rope may be damaged or broken. This may cause the platform to fall or tilt and consequently operators or objects might fall, resulting in serious injury or death to operators or passers-by.



**CAUTION**

**Do not touch the wire rope while the hoist is operating.**

There is a risk of fingers or the entire hand being pulled in with the wire rope. This may result in serious injury.

**[CAUTION: INSTALLATION]**

**! CAUTION**

**1. Do not throw or drop the hoist.**

The hoist may be damaged and cannot be operated. Also this may cause person to be injured or damage to property.

**2. Do not pull or step cables.**

Cables or connectors may be damaged and the hoist cannot be operated.

**STEP1 Installation of safety devices to BISOMAC**

Install BISOLOCK and BISOLOAD to BISOMAC.

See instructions below.

**[Components]**

**[Provided by NIHON BISOH]**

- BISOLOCK Mounting Bolt (2 pcs)
- M12 Plain Washer (2 pcs)
- M12 Nylon Nut (2 pcs)

**[Provided by NIHON BISOH]**

- Bolt for BISOLOCK Mounting Bracket (2 pcs)
- M12 Plain Washer (2 pcs)
- M12 Nylon Nut (2 pcs)

**[Provided by NIHON BISOH]**

- BISOLOAD Mounting Bolt B (2 pcs)
- M12 Plain Washer (4 pcs)
- M12 Nylon Nut (4 pcs)

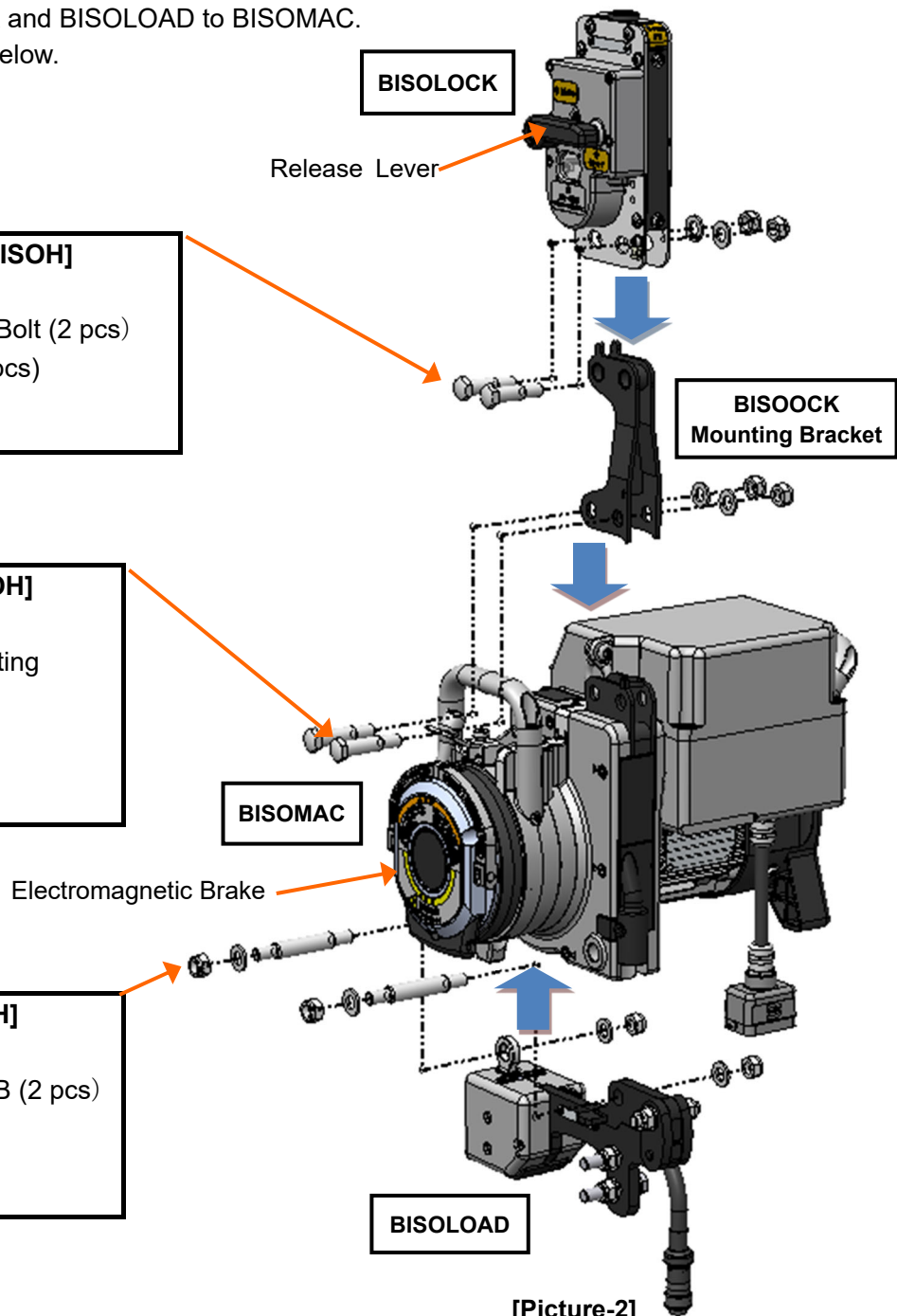

**[Picture-2]**

1. Set BISOLOCK mounting bracket to BISOMAC and fix with 2 pcs of bolt for BISOLOCK mounting bracket, 2 pcs of M12 Plain washer and 2 pcs of M12 Nylon nut.
2. Insert BISOLOCK to BISOLOCK mounting bracket from above and fix with 2 pcs of BISOLOCK mounting bolt, 2 pcs of M12 Plain washer and 2 pcs of M12 Nylon nut. Release Lever shall be Electromagnetic Brake side. (See Picture-2) Tighten the bolts with specified torque by using torque wrench.

Tightening torque: 76 N·m (770 kgf·cm)

3. Insert BISOLOAD to BISOMAC from below and fix with 2 pcs of BISOLOAD mounting bolt, 4 pcs of M12 Plain washer and 4 pcs of M12 Nylon Nut. (See Picture-2) Tighten the bolts with specified torque by using torque wrench.

Tightening torque: 76 N·m (770 kgf·cm)

## **STEP 2** Connecting to power supply



### **WARNING**

**Do not pull or step power cable of BISOMAC and connection cables of safety devices.**  
Cables may be damaged and cause electric shock. This may result in serious injury or death.



### **CAUTION**

**Use only suitable power cable and power source for BISOMAC.**  
Using incorrect power may cause overheating and damage to the cable and other components, and the Hoist will not work properly.

1. Connect the power cable of BISOMAC to power supply from central control box. Please check the types of connector. Followings are the model of female plugs.

Name	Model	Manufacturer
BISOMAC Socket	0933-006-2701	HARTING
BISOMAC Socket Cover	0930-006-0752	
BISOLOCK Socket	NJW-203AdF10	Nanahoshi Science Institute
BISOLOAD Socket	NJW-202AdF10	

2. Power requirements for one unit of BISOMAC.

Model	Ampere in Rated Load
BISOMAC308 3P-608MX	8.0A

3. Ensure that Emergency stop button on central control box and interlock of safety devices are not activated.
4. Ensure that current capacity and size of circuit breaker is adequate. (Refer to section 2)
5. Ensure that connectors are not cracked or damaged.

### **STEP 3** Installation of suspension wire rope

1. Insert the tip of suspension wire rope to wire rope inlet of BISOLOCK approximately 40 cm.
2. Push UP button while pushing wire rope in to BISOMAC lightly until suspension wire rope feeds automatically.
3. Make sure that suspension wire rope comes out from outlet without any obstruction and moves both up and down direction freely.
4. Distances between riggings and wire rope inlet of the Hoist when installed to the platform must be equal as suspension wire ropes are suspended vertically.
5. To prevent the platform from running off suspension wire ropes, secure the tail line as Picture-3

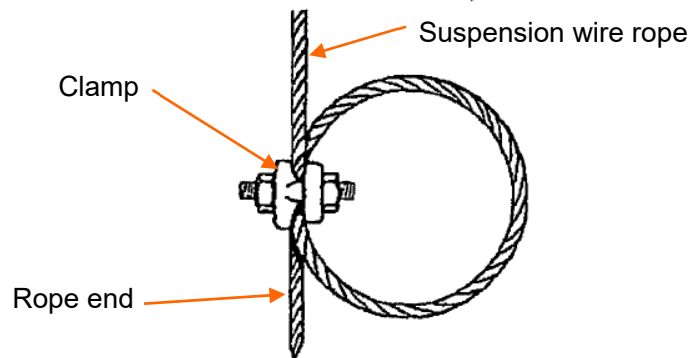

[Picture-3]

#### **STEP 4** Installation of the hoist

Press UP button and lift the platform from the ground. Align bolt passing holes of BISOLOAD and stirrup of the platform, then fix with 2 pcs of BISOMAC mounting bolt, 4 pcs of Plain washer M12, and 2 pcs of Nylon nut M12. (See Picture-6) The hoist shall be set as the exited wire ropes are positioned on the outer side of the platform. (See Picture-6)

Tighten the bolts with specified torque by using torque wrench.

Tightening torque: 76 N·m (770 kgf·cm)

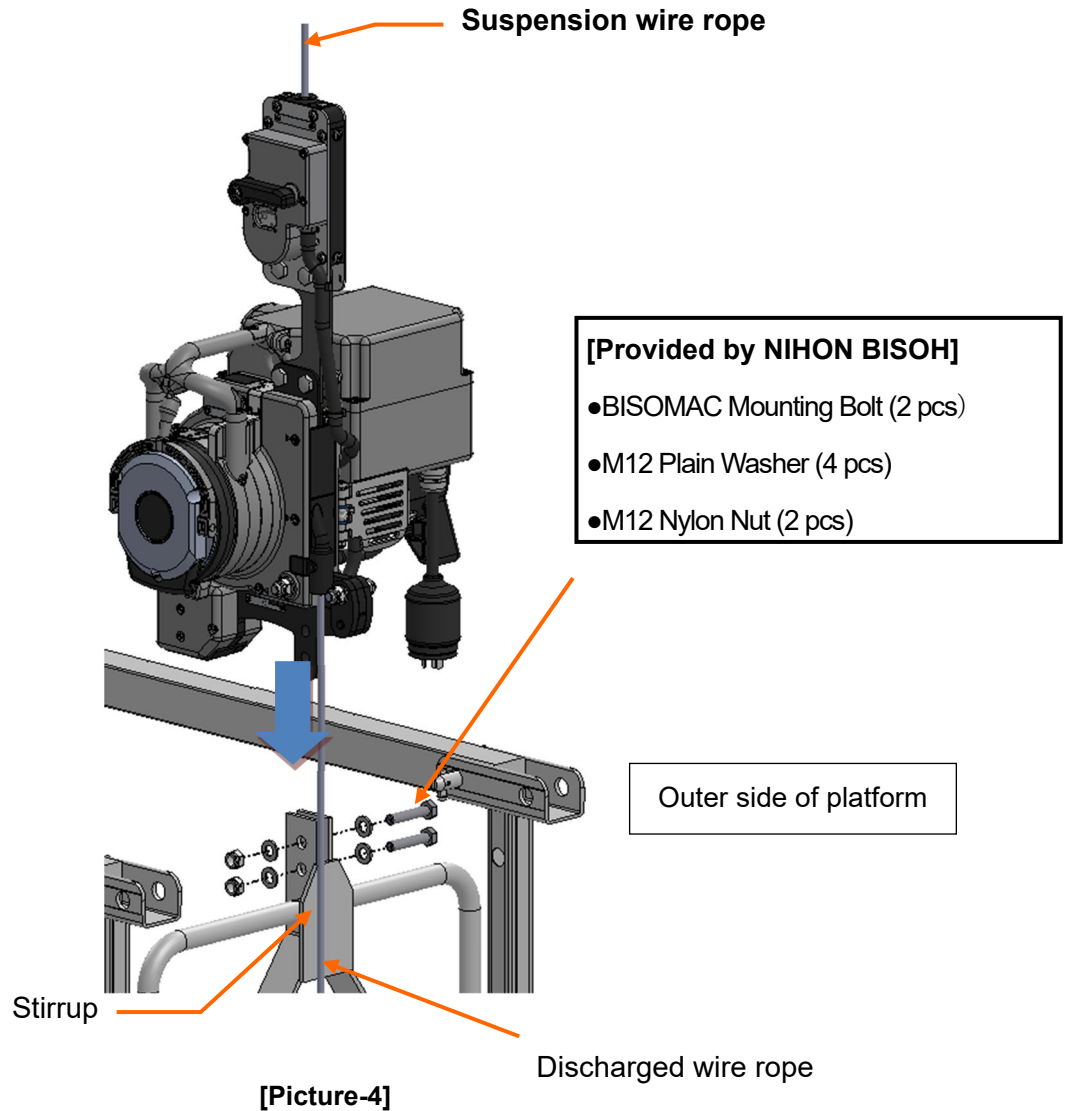

#### **STEP 5** Perform daily inspection

Perform daily inspection in accordance with section 7.

## 6. OPERATIING THE HOIST

This section describes the followings to handle and operate the hoist safely.

1. Carrying and storing the hoist.
2. Operation methods of the hoist.

### **WARNING**

- 1. Before operating the hoist each operator must understand and follow the instructions in this manual and labels on the hoist.**

Failure to comply with these instruction may cause the platform to fall or tilt and consequently operators or objects might fall, resulting in serious injury or death to operators or passers-by.

- 2. Do not overload on the platform.**

Suspension rig may fall down, resulting in serious injury or death to operators or passers-by.

### **CAUTION**

- Do not apply excessive load to shackle.**

Applying load exceeding 50 kg, shackle may be broken. It may cause the hoist to fall, resulting in injury or damage to property.

#### **[CAUTION: Carrying]**

### **CAUTION**

- 1. When carrying the hoist by hands, hold handle to carry.**

Unstable transporting may result in injury or damage to the hoist or property.

- 2. Do not use handle for any purpose other than carrying the hoist.**

If excessive load is applied to handle, the hoist may be broken. It may cause injury or damage to property.

#### **[CAUTION: Storage]**

### **CAUTION**

- When storing the hoist, remove BISOLOAD from BISOMAC.**

\*Refer to section 5 to remove BISOLOAD.

Storing with unstable state cause the hoist to fall down. It may cause injury or damage to the hoist.

**NOTE:** Do not stack BISOMAC more than 2 steps. Otherwise BISOMAC may fall down and be damaged.

**[WARNING: Lifting operation and Emergency stop]**

 **WARNING**

**1. Do not fix the operation switch in the pushed-in state.**

The hoist does not stop. It may cause the platform to fall or tilt and consequently operators or objects might fall, resulting in serious injury or death to operators or passers-by.

**2. Always allow BISOMAC to come to a full stop before changing the direction of travel.**

Otherwise the hoist may not stop properly due to control circuit failure. It may cause the platform to fall or tilt and consequently operators or objects might fall, resulting in serious injury or death to operators or passers-by.

**3. Do not use the hoist if Emergency stop switch does not work properly.**

In case of control circuit failure, the hoist does not stop operation. It may cause the platform to fall or tilt and consequently operators or objects might fall, resulting in serious injury or death to operators or passers-by.

**4. Push the operating switch by hand only.**

Using foreign objects to operate the hoist may damage to switch or switch cover and allow water to get in to the hoist. It may cause malfunction of the hoist and the platform to fall or tilt and consequently operators or objects might fall, resulting in serious injury or death to operators or passers-by.

 **CAUTION**

**Do not operate BISOMAC longer than 60 minutes during any 2 hours period.**

Otherwise Electromagnetic brake and Motor will become very hot and could result in burn injury.

**[WARNING: Remote control pendant switch]**

 **WARNING**

**1. Cable length of remote control pendant switch must be within the reach of operator to operate the Emergency Stop Switch on the central control box.**

Otherwise in case of emergency when operating from a distant, operator cannot operate Emergency Stop Switch of the Hoist. It may cause platform to fall or tilt and consequently operators or objects might fall, resulting in serious injury or death to operators or passers-by.

**2. Before connecting remote control pendant switch to the central control box, ensure that there is no water in the connector.**

Electric leakage due to inundation may cause malfunction or unintentional move. It may cause platform to fall or tilt and consequently operators or objects might fall, resulting in serious injury or death to operators or passers-by.



**[WARNING: Emergency controlled descent lever]**

 **WARNING**

**1. Use Emergency controlled descent lever only when power supply is cut off.**

After use, make sure to lock the Emergency controlled descent lever with lever stopper. Otherwise the Hoist may not stop during operation. It may cause the platform to fall or tilt and consequently operators or objects might fall, resulting in serious injury or death to operators or passers-by.

**2. Do not operate Emergency controlled descent lever when operating the Hoist with operating switch.**

The Hoist may not stop during operation and It may cause the platform to fall or tilt and consequently operators or objects might fall, resulting in serious injury or death to operators or passers-by.

**3. Before operating the Hoist, ensure that Emergency controlled descent lever is vertical and locked with lever stopper. (See Picture-5)**

The Hoist may not stop or the brake may not work properly. It may cause the platform to fall or tilt and consequently operators or objects might fall, resulting in serious injury or death to operators or passers-by.

**4. Operate Emergency controlled descent lever only by hand.**

The Hoist may not stop during operation and It may cause the platform to fall or tilt and consequently operators or objects might fall, resulting in serious injury or death to operators or passers-by.

**5. After using Emergency controlled descent lever, make sure that the lever is locked by lever stopper. (See Picture-5)**

The Hoist may not stop or the brake may not work properly. It may cause the platform to fall or tilt and consequently operators or objects might fall, resulting in serious injury or death to operators or passers-by.

 **CAUTION**

**1. Disconnect power cable from central control box when using Emergency controlled descent lever.**

Otherwise, sudden movement may be induced when the power is regained. This may cause injury or damage to property.

**2. Pull Emergency controlled descent lever as far as it goes toward by hand.**

If lowering down without releasing the brake completely, the Hoist may get overheated or the brake gets worn down and loses braking force. In this case, the brake may not be repairable.

**NOTE:** Do not use the Hoist if Emergency controlled descent lever does not work properly. Otherwise, in the event of power loss, the platform may not be able to descend and operator cannot escape. Such hoist must be repaired and retested before using.

## **6.1 Carrying the Hoist**

To safely transport the Hoist, detach BISOLOCK and BISOLOAD from BISOMAC. (Refer to STEP 1 in section 5)

BISOMAC self-weight : 37 kg

BISOLOCK self-weight : 3 kg

BISOLOAD self-weight : 3 kg

## **6.2 Operation methods of the Hoist**

### **6.2.1 Lifting and Emergency stop**

- Operate BISOMAC with operation switch on central control box.
- Press UP button to UP travel.
- Press DOWN button to DOWN travel.
- If Emergency stop button is pressed, power is cut off. The hoist shall not run in either direction.

## 6.2.2 Emergency controlled descent lever

•Allows downward travel at a controlled rate of speed in the event of power loss.

[Procedure of Emergency controlled descent]

1. Disconnect power plug from central control box.
2. Slide sliding knob and unlock lever stopper. (See Picture-10)
3. Release Electromagnetic brake by gently pulling Emergency controlled descent lever as far as it goes toward the arrow shown in Picture-11. The hoist will travel downward at a controlled rate of speed.
4. The hoist stops when Emergency controlled descent lever is released.

**NOTE:** Do not apply excessive force to Emergency controlled descent lever. Emergency controlled descent lever may be damaged and consequently unable to descend in the event of emergency. If Emergency controlled descent lever is broken, refer to Maintenance Procedure Manual (separately issued).

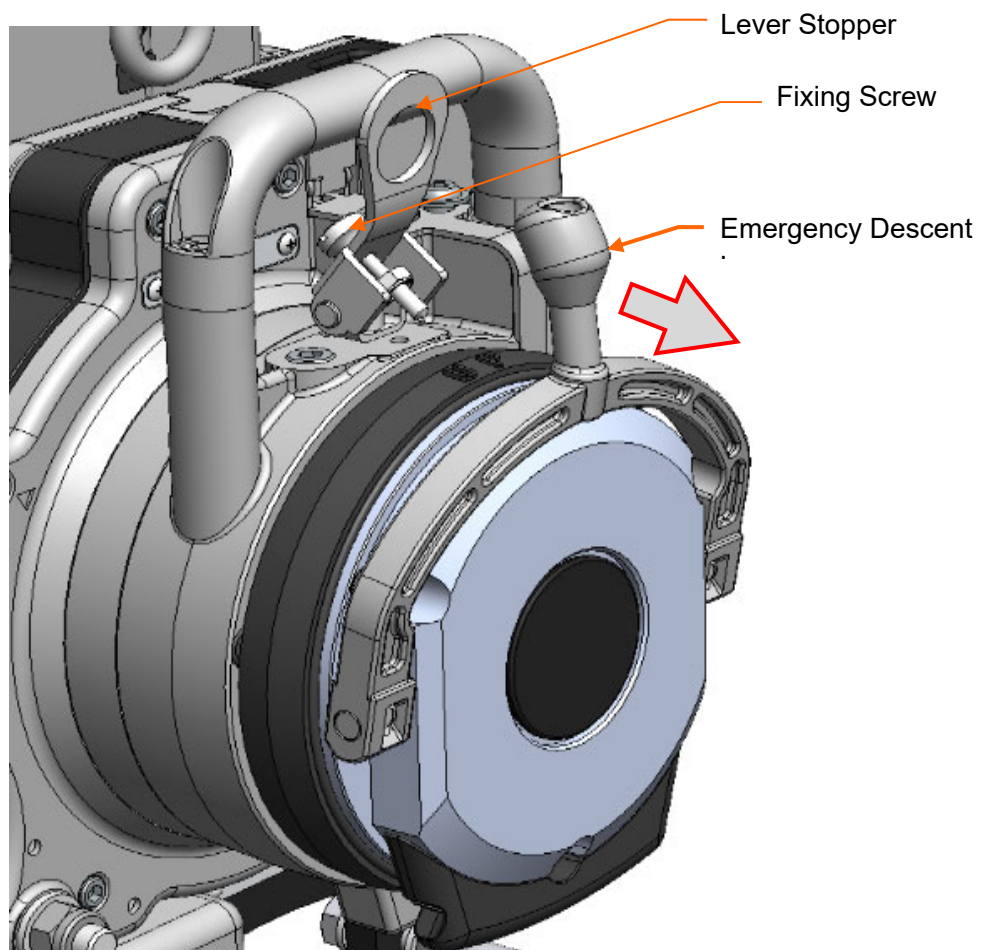

[Picture-5]

### 6.2.3 Releasing procedure of BISOLOCK

#### **WARNING**

**If BISOLOCK is activated, do not release it until safety is confirmed.**

It may cause the platform to fall or tilt and consequently operators or objects might fall, resulting in serious injury or death to operators or passers-by.

#### **[How to reset BISOLOCK]**

1. Operate UP travel to reeve wire rope approximately 5 cm.
2. Pull down Release Lever and deactivate BISOLOCK. (See Picture-6)  
\*Release lever can be easily released by pressing down the release lever while operating DOWN travel.
3. Check if BISOLOCK is released by following procedure.
  - Activation indicator lamp is unlit.
  - Release lever is at horizontal and activation indicator lamp is hid by the lever.

**NOTE:** DO NOT forcibly push down the release lever to reset. Pin inside BISOLOCK may be damaged and may cause BISOLOCK not to be able to be released. Make sure to have the platform be safe and stable state before releasing BISOLOCK.

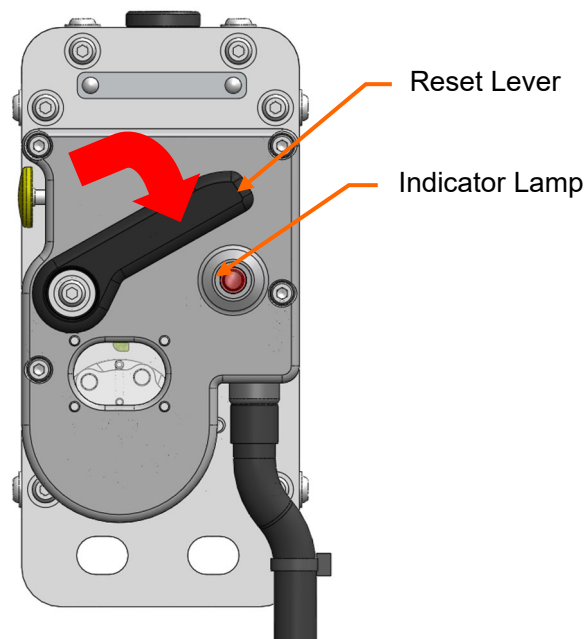

**[Picture-6]**

## 7. DAILY TESTS AND INSPECTIONS

This section describes procedure of daily tests and inspections. Do not use the hoist until following tests and inspections have been completed to ensure correct operation.

- Read 7.1-7.3 and fully understand procedures of tests and inspections.
- Devices and parts not described in this manual, follow manuals of each device and part.

### **WARNING**

#### **1. Do not allow anyone under suspended platform.**

Objects might fall, resulting in serious injury or death to passers-by.

#### **2. Never perform any disassembly, maintenance, repair, or part replacement of the hoist when it is suspended in the air or is under load.**

Platform may fall or tilt and consequently operators or objects might fall, resulting in serious injury or death to operators or passers-by.

#### **3. Perform all tests and inspection at the start of each work shift.**

The hoist may malfunction. This may cause the platform to fall or tilt and consequently operators or objects might fall, resulting in serious injury or death to operators or passers-by.

#### **4. Daily tests and inspections must be performed carefully according to this manual**

Correct operation of the hoist must be ensured. Otherwise, platform may fall or tilt due to malfunction and consequently operators or objects might fall, resulting in serious injury or death to operators or passers-by.

#### **5. Using the hoist in severe environment, perform tests and inspections more frequently. (Refer to section 4)**

Perform disassemble maintenance after completing work at each project site to remove dusts and contaminations from BISOMAC and BISOLOCK inside and perform inspection. Otherwise, accumulated dusts and contaminations bother proper operation of the hoist. This may cause the platform to fall or tilt and consequently operators or objects might fall, resulting in serious injury or death to operators or passers-by.

### 7.1 Tests and Inspection: Rigging materials

#### **[WARNING: Tests and inspections of rigging materials]**

### **WARNING**

**If any abnormalities are found on rigging materials, do not use the platform with such faulty materials.**

Wire ropes may be cut or run off from the suspension rig. This may cause the platform to fall or tilt and consequently operators or objects might fall, resulting in serious injury or death to operators or passers-by.

Inspect all rigging materials which support load of the equipment (such as nut, bolt, clamp, wire clip, shackle, and so on) and wire ropes. Ensure that they are not damaged or worn down and that they are secured properly.

## 7.2 Test and Inspection: Wire Rope

[WARNING: Tests and inspections of wire rope]



### WARNING

**Inspect wire ropes periodically. If any abnormalities are found, replace with new one.**

Wire rope is worn down by repeated using. Damaged or deformed wire rope may be cut due to loss of strength. This may cause the platform to fall or tilt and consequently operators or objects might fall, resulting in serious injury or death to operators or passers-by.

### 7.2.1 Shape and size of wire rope

- Replace wire rope if any of below conditions are found. (See Photo-1 below)



[Photo-1]

1. Waviness (wave greater than 4/3 times of nominal diameter. (See Picture-12)

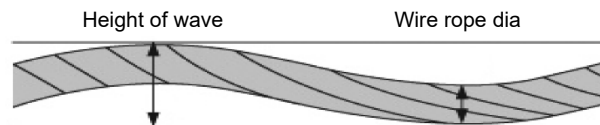

[Picture-7]

2. When loosened wires, deformation, or kink are found.
3. Broken wires which more than 10% of total number of wires per one pitch of wire rope.  
(Picture-13 shows one pitch of 6 strands wire rope)

\*Ex. Construction of wire rope is 6x19:  $6 \times 19 \times 10\% = 114 \times 0.1 = 11$  wires



[Picture-8]

4. Average diameter of 9.0 mm wire rope becomes 

}	smaller than 7.8 mm.
	greater than 8.4 mm.
5. Heavily rusted and found pitting on surface.
6. Wire rope that has been exposed to temperature above 93°C.

- Measure the diameter of wire rope as shown in Picture 9 and 10 below.

Measure the diameter of circumscribed circle of wire rope while load is applied. Measure 2 diameters per one circumference at different direction, and average the values. Diameter shall be measured several positions in the direction of length.

Wire rope with even number of strands shall be measured its largest cross section as shown in Picture-9.

Wire rope with uneven number of strands shall be measured with a board as shown in Picture-10. Value without thickness of the board is the diameter of wire rope.

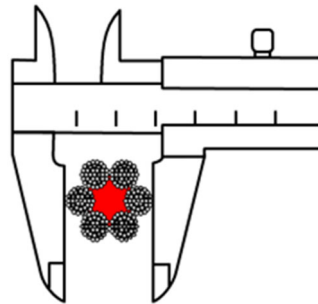

[Picture-9]

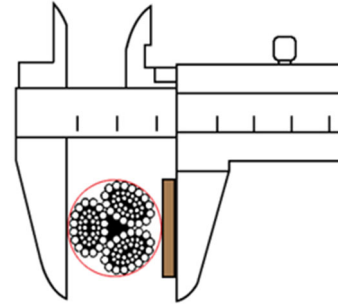

[Picture-10]

**NOTE:** Worn, kinked, or deformed wire rope and wire rope with broken wires or waviness cannot be repaired, must be replaced.

### 7.2.2 Shape and size of the end of wire rope

- For using with the hoist, the end of wire rope shall be shaped as shown in the Photo-2.

**NOTE:** If the shape of the end of wire rope is not proper, wire rope may not be inserted to the hoist, or may be jammed inside the hoist and cannot be discharged.

- The end of wire rope shall be shaped as below.

Nominal Diameter	8.0 mm wire rope
Diameter [A]	8.0-8.4 mm
Brazed portion [B]	Within 10.0 mm
Radius of top end [R]	3.0 mm

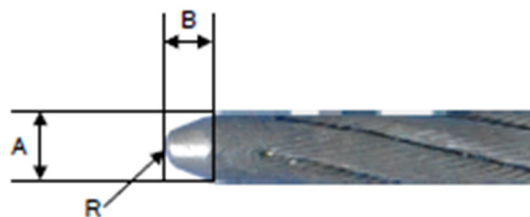

[Photo-1]

### 7.3 Test and Inspection: Hoist

 **WARNING**

**Do not use the hoist if any defect is found. Authorized personnel must replace with the hoist which inspected and passed all test.**

Otherwise, malfunction may occur. This may cause the platform to fall or tilt and consequently operators or objects might fall, resulting in serious injury or death to operators or passers-by.

 **CAUTION**

**If oil is leaking from BISOMAC, stop using immediately and replace with the hoist which inspected and passed all test.**

Lacking oil cause Gear Box and Motor to overheat. This may cause burn injury to operator. Also, the overheating may cause serious damage to Gear Box and Motor. Smoke may be emitted, the hoist may become unable to work.

#### **Pre-operation inspection**

- Ensure that bolts, nuts, and cap of operator's manual storage of the hoist are not loosened.
- Visually inspect the appearance of the hoist (including cables and connectors) and ensure that there are no damaged parts.
- Ensure that the hoist is properly installed to the platform.
- Ensure that central control box (including circuit breaker) is connected to power supply.



### 7.3.1 Tests and inspections: Lifting the platform and emergency stop function

#### [WARNING: Lifting operation and emergency stop function]

#### **WARNING**

**1. Stop operating the hoist immediately if any defect such as abnormal noise is found. Replace with the hoist which inspected and passed all tests.**

Do not use abnormal hoist. Parts inside the hoist may be damaged. Continued using may cause the platform to fall or tilt and consequently operators or objects might fall, resulting in serious injury or death to operators or passers-by.

**2. Stop operating immediately if wire rope does not travel through the hoist while the platform is suspended even motor is working.**

Wire rope may be jammed inside the hoist or sheave may be slipping. Continued using may result in damage to the equipment or wire rope to cut off. This may cause the platform to fall or tilt and consequently operators or objects might fall, resulting in serious injury or death to operators or passers-by.

**3. Do not use the hoist if Emergency stop switch does not work.**

In the event of failure in circuit, the hoist may not be able to stop properly. This may cause the platform to fall or tilt and consequently operators or objects might fall, resulting in serious injury or death to operators or passers-by.

**4. Operate Emergency stop switch and operation switch only by hand.**

Using foreign objects to operate the hoist may damage to switch or switch cover and allow water to get in to the hoist. It may cause malfunction of the hoist and the platform to fall or tilt and consequently operators or objects might fall, resulting in serious injury or death to operators or passers-by.

**5. Stop operating immediately if the hoist travels to wrong direction.**

This may cause the platform to fall or tilt and consequently operators or objects might fall, resulting in serious injury or death to operators or passers-by.

#### [Inspection procedure /Central control box]

1. Lift up the platform by operating the central control box approximately 1 m from the ground and lower down to the ground again. Repeat this process several times to check if there is no abnormal vibration such as the hoist is shaking.
2. Check if Hour meter works properly.
3. Press Emergency stop switch on the central control box to cut off the power to the hoist.
4. Ensure that the hoist does not operate even operation switch on the central control box is operated.
5. Reset Emergency stop switch on the central control box. Ensure that the hoist resumes its normal operation.

**[WARNING: Remote control pendant switch]**

 **WARNING**

**If the Hoist continue operating even Emergency Stop Switch on the remote control pendant switch is pressed, stop using immediately and replace with normal one.**

Control circuit of the Hoist or remote control pendant switch may be defected. In case of emergency, the platform may not stop due to the defective remote control pendant switch. It may cause platform to fall or tilt, and consequently operators or objects might fall, resulting in serious injury or death to operators or passers-by.

**[Inspection procedure / Remote control pendant switch]**

1. Lift up the platform by operating remote control pendant switch approximately 1 m from the ground and lower down to the ground again. Repeat this process several times to check if there is no abnormal vibration such as the hoist is shaking.
2. Check if Hour meter works properly.
3. Press Emergency stop switch on the remote control pendant switch to cut off the power to the hoist.
4. Ensure that the hoist does not operate even operation switch on the remote control pendant switch is operated.
5. Reset Emergency stop switch on the remote control pendant switch. Ensure that the hoist resumes its normal operation.

**7.3.2 Tests and inspections: Controlled descent function**

 **CAUTION**

**1. Disconnect power cable from central control box when operate Emergency controlled descent lever.**

Otherwise, sudden movement may be induced when the power is regained. This may cause injury or damage to property.

**2. Pull Emergency controlled descent lever as far as it goes toward by hand.**

If lowering down without releasing the brake completely, the Hoist may get overheated or the brake gets worn down and loses braking force. In this case, the brake may not be repairable.

1. Lift up the platform approximately 1 m from the ground.
2. Disconnect power cable from central control box to cut off the power.
3. Release lever stopper.
4. Pull Emergency controlled descent lever gently and lower the platform.
5. Check if the platform descends at a slow, controlled speed.

**NOTE:** If the platform descends with increasing speed, release hand from the lever immediately and contact local distributor.

### 7.3.3 Tests and inspections: BISOLOCK

#### [WARNING: Tests and inspections of BISOLOCK]

#### **WARNING**

**If BISOLOCK does not hold wire rope properly, stop using immediately and replace with normal product.**

Otherwise in the event slippage or cut of wire rope, BISOLOCK may not hold wire rope and consequently operators or objects might fall, resulting in serious injury or death to operators or passers-by.

#### [Inspection procedure / BISOLOCK]

1. Lift up the platform approximately 20 in (approx. 50 cm).
2. Press Trip Button to activate BISOLOCK.
3. Pull Emergency Controlled Descent Lever and lower the platform.
4. BISOLOCK holds wire rope and stop lowering.
5. Confirm that the Hoist does not work even DOWN button is pressed.
6. Confirm that Overspeed indicator lamp lights up when DOWN button is pressed.
7. Ascend the platform and pull down Release Lever to deactivate BISOLOCK.
8. Confirm that UP/DOWN operation is operable.  
Also confirm that Governor is rotating while the platform is ascending/descending.  
Apply same procedure to another BISOLOCK.

**NOTE:** If BISOLOCK does not hold wire rope properly, contact local distributor to replace.

#### [CAUTION: Activation of BISOLOCK]

#### **CAUTION**

**1. Trip Button must be operated only by hand.**

Trip Button may be broken and cause BISOLOCK unable to be activated normally.

**2. DO NOT forcibly release BISOLOCK.**

Safety pin inside Release Lever may be broken and cause BISOLOCK unable to be deactivated.

#### [Activation check of BISOLOCK]

1. Insert wire rope to BISOLOCK approximately 30 cm.
2. Pull out wire rope quickly.
3. Confirm that BISOLOCK holds wire rope firmly.
4. Confirm that activation indicator lamp lights up when DOWN button is pressed.
5. Reset BISOLOCK by pulling down Release Lever. (Picture-6)
6. Confirm that activation indicator lamp does not light up when DOWN button is pressed.

**NOTE:** If BISOLOCK is not activated and the platform continue falling, press Trip Button to manually activate BISOLOCK.

## 8. PERIODIC MAINTENANCE

Periodic maintenance must be performed by authorized personnel if the Hoist corresponds to any of following conditions.

1. 1 year from purchase
2. 1 year from last periodic maintenance
3. 100 hours from last periodic maintenance
4. The Hoist is used in a dirty environment

NOTE: Above periods are at the latest, under proper use according to this manual. Since actual use conditions are uncertain, appropriate maintenance cycle shall be determined depending on the actual conditions and referring to above periods.

\*Procedure of Periodic Maintenance, refer to Maintenance Procedure Manual of each device. (Separately issued)

### **WARNING**

**1. Repairs of component parts of the Hoist shall be performed only by authorized personnel.**

Otherwise, the Hoist may malfunction or unable to operate normally. This may cause the platform to fall or tilt and consequently operators or objects might fall, resulting in serious injury or death to operators or passers-by.

**2. Use only parts authorized by manufacturer for replacement.**

1. Otherwise, the Hoist may malfunction or unable to operate normally. This may cause the platform to fall or tilt and consequently operators or objects might fall, resulting in serious injury or death to operators or passers-by.

## 9. TROUBLESHOOTING AT JOB SITE

### [Mishandling]

This section describes possible troubles caused by mishandling and solutions for such troubles.



### WARNING

**If the Hoist does not get back its normal condition even following solutions (Case I-X) have been attempted, contact local distributor and replace.**

Repairs and corrective actions shall be performed only by authorized and properly trained personnel. Improper repairs and corrective actions may cause serious accidents.

#### Case I The Hoist does not run.

Possible cause	Solution
<ol style="list-style-type: none"> <li>1. Power is off.</li> <li>2. Emergency Stop Switch is activated.</li> <li>3. Overload protection is activated.</li> </ol>	<ol style="list-style-type: none"> <li>1. Connect AC power plug properly.</li> <li>2. Deactivate Emergency Stop Switch.</li> <li>3. Unload from the platform. Use the hoist within the designated temperature range (section 2.1).</li> </ol>

#### Case II The Hoist runs and able to descend but unable to ascend or ascend but pumps.

Possible cause	Solution
<ol style="list-style-type: none"> <li>1. BISOLOAD is disconnected.</li> <li>2. BISOLOAD is activated due to overloading</li> <li>3. Insufficient voltage.</li> <li>4. Power cable is too long or too small.</li> </ol>	<ol style="list-style-type: none"> <li>1. Connect BISOLOAD properly.</li> <li>2. Check Overload indicator lamp and unload from the platform.</li> <li>3. Check Voltage meter if sufficient voltage is supplied.</li> <li>4. Replace power cable to shorter or thicker one.</li> </ol>

#### Case III Motor runs normally but wire rope is not reeved.

Possible cause	Solution
<ol style="list-style-type: none"> <li>1. Poor bullet.</li> <li>2. Wire rope is kinked or deformed.</li> <li>3. Dirt or other material is obstructing inside or rope exit of the Hoist.</li> </ol>	<ol style="list-style-type: none"> <li>1. Retouch rope end as instructed. (section 7.2)</li> <li>2. Stop operating and replace wire rope immediately.</li> <li>3. Clean out rope exit.</li> </ol>

<b>Case IV The Hoist reeves wire rope but the platform is not lifted.</b>	
Possible cause	Solution
1. Improper wire rope is used. 2. Defective wire rope (worn out, broken wire, deformation, etc.)	1. Replace with designated wire rope. (section 2.4) 2. Replace with normal wire rope.

<b>Case V Lifting speed is too slow.</b>	
Possible cause	Solution
1. Insufficient voltage. 2. Defective wire rope (worn out, broken wire, deformation, etc.)	1. Replace power cable with proper one or supply sufficient voltage. (section 2.1) 2. Replace with normal wire rope.

<b>Case VI Unusual noises come from the Hoist or safety devices.</b>	
Possible cause	Solution
1. Insufficient oil in Gear box. 2. Damaged or broken gears. 3. Contamination inside the devices. 4. Defect inside the devices. 5. Loosened bolts and nuts. 6. Improper wire rope is used.	1-4. Replace the Hoist.  5. Check and tighten each bolt and nut. 6. Replace with designated wire rope.(section 2.4)

<b>Case VII BISOMAC becomes very hot.</b>	
Possible cause	Solution
1. Voltage is too high. 2. Insufficient ventilation for Motor. 3. Heavily used. 4. Excessive load to the Hoist.	1. Supply rated voltage +/- 10%. (section 2.1) 2. Improve ventilation. 3. Keep rated operating time. (section 6) 4. Check if the weight of the platform and applied loads are appropriate to the Hoist. If necessary, reduce the load.

<b>Case VIII The Hoist ascends with UP button but cannot descend with DOWN button.</b>	
Possible cause	Solution
1. BISOLOCK is disconnected. 2. BISOLOCK is activated.	1. Connect BISOLOCK properly. 2. Reset BISOLOCK. Refer to section 6.2.3 how to release BISOLOCK. Ensure that there are no safety issues before releasing.

<b>Case IX The wire rope cannot be inserted</b>	
Possible cause	Solution
1. BISOLOCK is not released.  2. Dust is accumulated in BISOLOCK. 3. The tip of the wire rope is deformed. 4. Improper fusion cutting of wire rope end. 5. Wire rope is not suitable.	1. Reset BISOLOCK. Refer to section 6.2.3 how to release BISOLOCK. Ensure that there are no safety issues before releasing.  2. Replace with normal BISOLOCK. 3 - 5 Use a suitable wire rope for BISOLOCK. (Refer to section 2.2 and 7.2)

<b>Case X BISOLOCK operates unintentionally.</b>	
Possible cause	Solution
1. Malfunction due to vibration, etc.  2. Damage to BISOLOCK internal components 3. Wire rope is kinked or deformed.  4. Diameter of wire rope is too thick.	1. Check if there are any safety problems, and release it if there are no problems. (section 6.2) 2. Replace with normal BISOLOCK. 3. Stop the operation immediately and replace with normal wire rope. 4. Check the diameter of wire rope and replace with appropriate wire rope. (section 7.2)

# Wiring diagram of BISOMAC308 3P-608MX

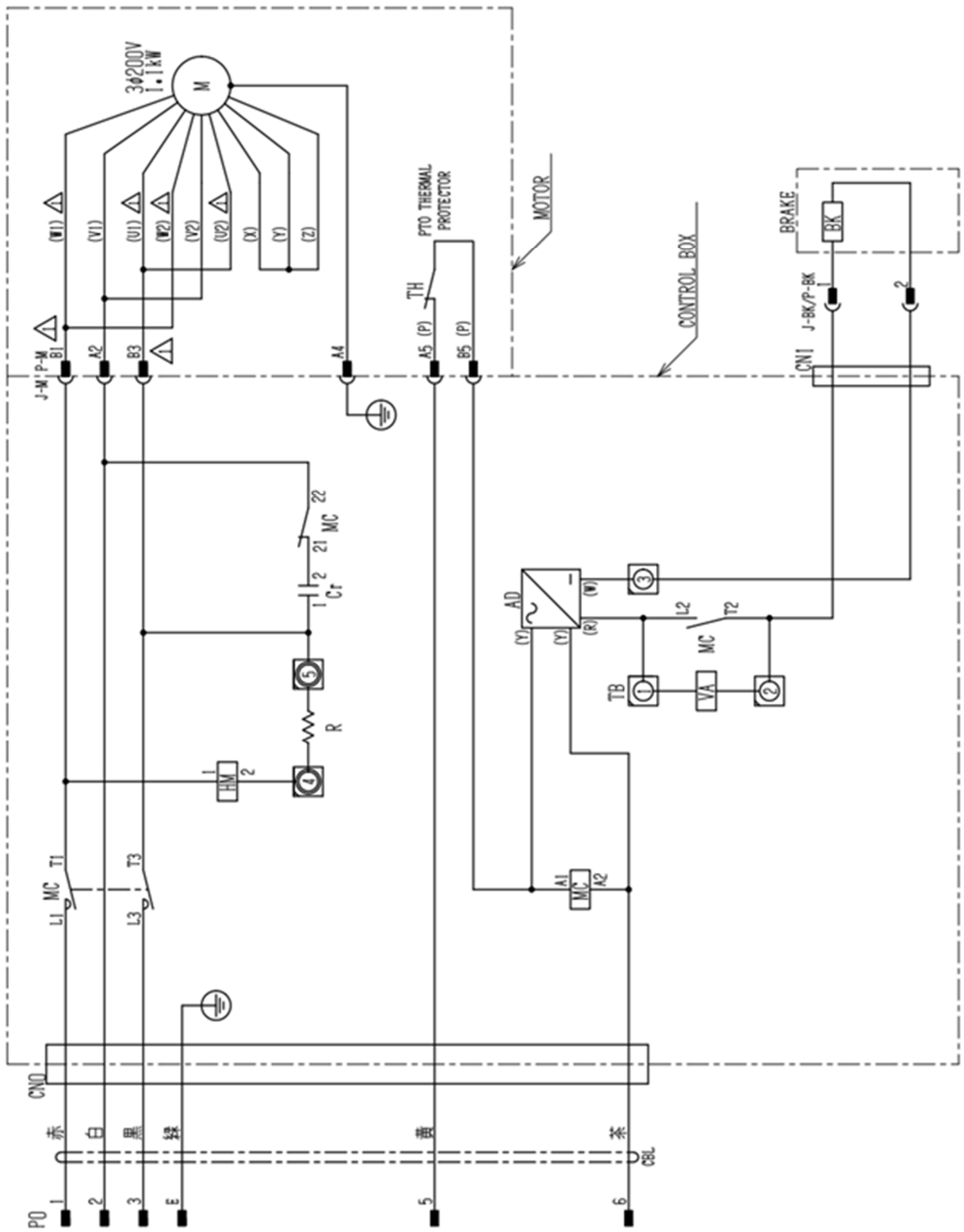



## Revision History

Revision 1: November 17, 2020

1. Corrected errors.
2. Added BISOLOCK and BISOLOAD to safety devices.

Revision 2: November 22, 2021

1. Corrected errors.
2. Standardized the naming of wire rope (Japanese version only).
3. Standardized the representation of the unit.
4. Added replacement criteria of wire rope.
5. Changed the length of brazed portion of the end tip of wire rope.
6. Added troubleshooting.

Revision 3: March 13, 2023

1. Corrected errors.
2. Changed sentences.
3. Added storage procedure.
4. Added warranty exemption conditions.
5. Changed location of the label "Manual mark".
6. Changed [Photo-2].
7. Added troubleshooting.



**BISOMAC308 Specifications for Latin America  
Electric Traction Hoist  
Operator's Manual**

<p>Date of issue:</p> <table><tr><td>January 20, 2020</td><td>First edition</td></tr><tr><td>November 17, 2020</td><td>Revision 1</td></tr><tr><td>November 22, 2021</td><td>Revision 2</td></tr><tr><td>March 13, 2023</td><td>Revision 3</td></tr></table>	January 20, 2020	First edition	November 17, 2020	Revision 1	November 22, 2021	Revision 2	March 13, 2023	Revision 3	<p>Published by:</p> <p>Overseas Department <b>NIHON BISOH CO., LTD.</b> 3788 Hinami, Togitsu-cho, Nagasaki, 851-2108 Japan TEL: 81-95-882-1925 FAX: 81-95-881-0177 URL: <a href="http://www.bisoh.co.jp/en">www.bisoh.co.jp/en</a></p>
January 20, 2020	First edition								
November 17, 2020	Revision 1								
November 22, 2021	Revision 2								
March 13, 2023	Revision 3								