BISOMAC210 Pneumatic Traction Hoist Operator's Supplement Manual

**Models: BISOMAC210-1000A
BISOMAC210-1508A
BISOMAC210-1500A**



WARNING:

This supplement is a continuation of the BISOMAC210 Operator's Manual. Read both the manual AND the supplement before operating hoist. Failure to follow the safety precautions and instructions in the manual and the supplement could result in serious injury, death or damage to the hoist.

Contents:

	PAGE
1. READ BEFORE USING BISOMAC210 PNEUMATIC TRACTION HOIST	3
2. FOR SAFE USE:	3
2.1. GENERAL	3
2.2. CATEGORIES OF SAFETY INSTRUCTIONS	4
3. SPECIFICATIONS:	10
3.1. BISOMAC210 TRACTION HOIST	10
3.2. OVERSPEED DETECTION DEVICE	11
3.3. FILTER, REGULATOR AND LUBRICATOR	11
4. FUNCTION AND DESCRIPTION OF EACH COMPONENT:	12
4.1. BISOMAC210 PNEUMATIC TRACTION HOIST	12
4.2. FILTER, REGULATOR AND LUBRICATOR	15
4.3. FILTER, REGULATOR AND LUBRICATOR ASSEMBLY	16
5. SET UP / INSTALLATION:	17
5.1. HOIST ASSEMBLY	17
5.2. CONNECTION OF AIR SUPPLY	18
5.3. INSTALLING THE BISOMAC210 ONTO THE STIRRUP	19
5.4. CONFIRMING OPERATION OF OVERSPEED DETECTION DEVICE	19
6. OPERATING INSTRUCTIONS:	21
6.1. REEVE WIRE ROPE	21
6.2. HOIST OPERATION	21
6.3. EMERGENCY DESCENT LEVER OPERATION	21
6.4. EMERGENCY ASCENT WHEEL OPERATION	22
7. PERIODIC INSPECTIONS	22
8. TROUBLESHOOTING AT JOB SITE	22

1. READ BEFORE USING BISOMAC210 PNEUMATIC TRACTION HOIST

This Operator's Supplement Manual has been prepared for the safe and proper operation of the **BISOMAC210 Pneumatic Traction Hoist** (referred to as "BISOMAC210"). To understand the usage of the BISOMAC210 Pneumatic Traction Hoist, please refer to the BISOMAC210 Electric Traction Hoist Operator's Manual. After completely reading the BISOMAC210 Electric Traction Hoist Operator's Manual, proceed to reading this supplement manual.

This supplement is a continuation of the BISOMAC210 Electric Traction Hoist Operator's Manual. Read both the manual AND the supplement before operating hoist. Failure to follow the safety precautions and instructions in the manual and the supplement could result in serious injury, death or damage to the hoist. It is operator's responsibility to be sure that the hoist is used safely and properly.

2. FOR SAFE USE:

2.1 GENERAL

This Operator's Supplement Manual (referred to as "Supplement") is applicable to the BISOMAC210 Pneumatic Traction Hoist and has been prepared for the safe and proper operation of the BISOMAC210. The BISOMAC210 consists of the Hoist Device (referred to as "Hoist") and the Overspeed Detection Device.

1. Read and understand this supplement fully before using the BISOMAC210.
2. This BISOMAC210 is designed for vertical ascent and descent of personnel-carrying suspended platforms. The BISOMAC210 should only be used for this purpose.
3. All operators must be fully trained in the use of the equipment including its safety features.
4. Daily Tests and Inspections described in the BISOMAC210 Electric Traction Hoist Operator's Manual: Section 7 must be performed at the start of each work shift.
5. Use Section 7 troubleshooting guide in this supplement to solve problems that may develop with the BISOMAC210. Understand the problem before attempting to solve it.

It is very important that anyone using the BISOMAC210 determine for themselves whether the BISOMAC210 is safe. You must be familiar with the operating characteristics of the BISOMAC210. You must understand how the BISOMAC210 will interact with other equipment and it is very important to confirm safety of the whole platform. You must also be certain not to jeopardize yourself or others, or cause damage to the surroundings, or the BISOMAC210.

Handling, maintenance, inspections and repairs of the following products must be performed by trained personnel only who have been read the BISOMAC210 Maintenance Manuals (another sheet).



BISOMAC210 consists of:

- 1) Hoist Device
- 2) Overspeed Detection Device

There are individual maintenance manuals for the hoist and safety devices.



2.2 CATEGORIES OF SAFETY INSTRUCTIONS

In this supplement, the safety instructions are classified according to risk levels.

Simple	Code Word	Meaning
	WARNING	Indicates a potentially hazardous situation which, if not avoided, could result in death or serious injury.
	CAUTION	Indicates a potentially hazardous situation which, if not avoided, may result in minor or moderate injury. It may also be used to show potential damage to property.
	NOTE	Indicates a potentially hazardous situation which, if not avoided, could result in damage of the BISOMAC210.

Warning labels attached to Hoists and Devices:

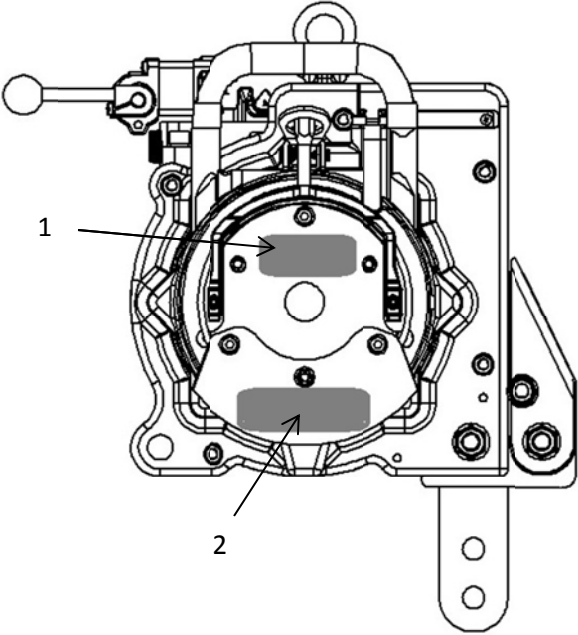
The operator must check that the following labels are attached properly and legible.

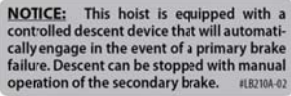
[BISOMAC210 Right Side]			
			
##	Description	Message / <Location>	Label
1	Emergency Control Descent	Emergency Control Descent Warning <Brake Assembly>	
2	Control Descent Instruction	Instructions for Controlled descent feature <Brake Cover Assembly>	

[BISOMAC210 Top Side]

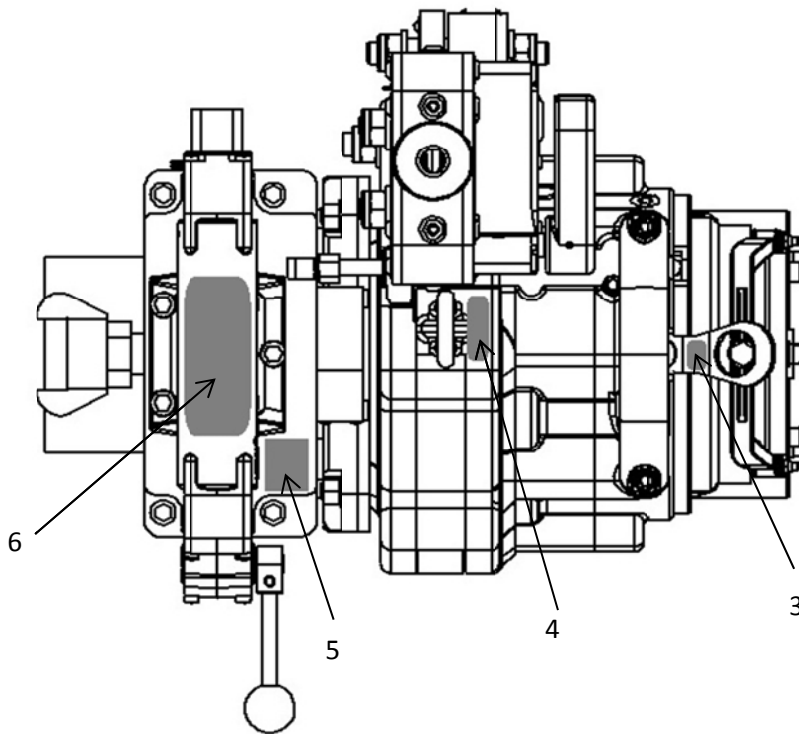

##	Description	Message / <Location>	Label
3	Lever Stopper	Instruction of Brake Release Lever Stopper <Lever Stopper>	
4	Max Lift	Instruction of Shackle max lift <Casing A>	
5	UP / DOWN	UP / DOWN Indicator <Manifold Top>	
6	Model Specifications	Model: BISOMAC210-1000A Specifications <Valve>	
6	Model Specifications	Model: BISOMAC210-1508A Specifications <Valve>	
6	Model Specifications	Model: BISOMAC210-1500A Specifications <Valve>	

[BISOMAC210 Left Side]

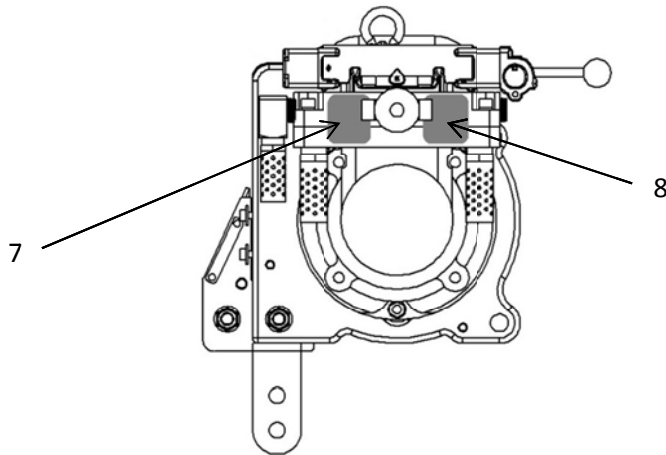

##	Description	Message / <Location>	Label
7	Operating Instructions	Hoist Operating Instructions <Manifold Assembly>	<p>OPERATING INSTRUCTIONS: #B210A-04</p> <ol style="list-style-type: none"> 1. To remove the wire rope, insert "bullet" end about 18 in, until it stops. Push up on the operating lever and it will self-reeve. 2. To operate the hoist, push the operating lever in the UP or DOWN direction until the desired height is reached and then release the operating lever to stop travel. 3. If air pressure fails, use the Emergency Controlled Descent feature to lower the platform. SLOWLY pull on the Emergency Descent Lever. USE FOR EMERGENCY ONLY.
8	CAUTION:	CAUTION Label <Manifold Assembly>	<p>CAUTION:</p> <ol style="list-style-type: none"> 1. READ and understand the Operating Manual before use. 2. ONLY use wire rope that complies with the BISOMAC210 Hoist Specifications. 3. Inspect Hoist and test all safety devices before each use. DO NOT USE unless all safety devices are operating properly. 4. ONLY trained and authorized personnel shall operate this hoist in strict conformity with federal and local regulations affecting the use of this equipment. #B210A-05

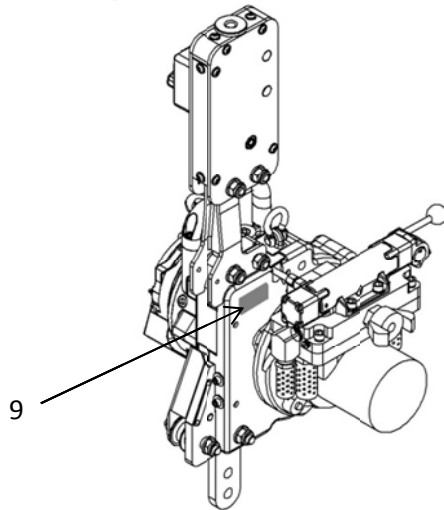

[BISOMAC210 Front Side]



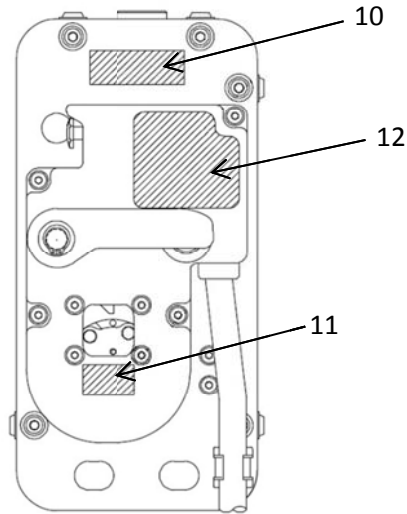

##	Description	Message / <Location>	Label
9	UL Classification	UL Certification Label < Casing B >	
9	CUL Classification	CUL Certification Label < Casing B >	

[Overspeed Detection Device Right Side]



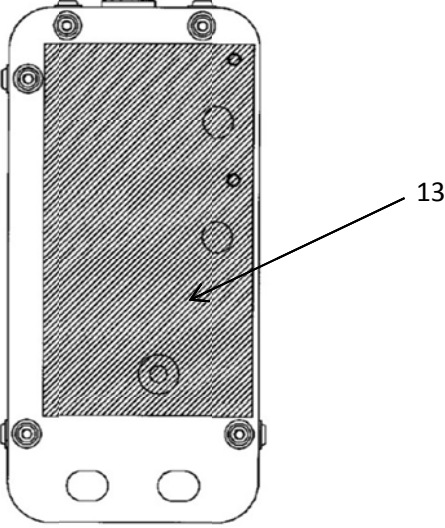

##	Description	Message / <Location>	Label
10	Instruction of inability of lifting	Instruction to inability of lifting <Side Plate 1>	
11	Governor Inspection Window	Instruction of Governor Rotation <Governor Cover>	
12	Overspeed Indicator & Reset	Instruction of Overspeed Detection Device <Governor Cover>	

[Overspeed Detection Device Left Side]			
			
##	Description	Message / <Location>	Label
13	Instruction of Overspeed Detection Device	Instruction of Overspeed Detection Device <Side Plate 2>	

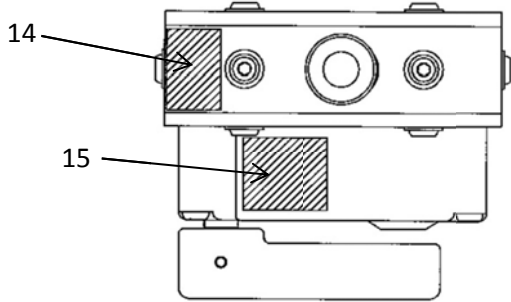
[Overspeed Detection Device Top Side]



##	Description	Message / <Location>	Label
14	Wire Rope Diameter	Instruction of Wire Rope Diameter <Side Cover 1>	
15	Instruction of Manual Trip Button	Instruction of Manual Trip Button <Governor Cover>	

[Stirrup Bar Back Side]

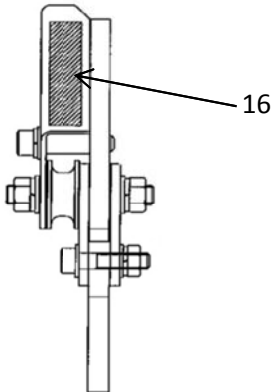

##	Description	Message / <Location>	Label
16	Wire Rope Exit	Instruction of Wire Rope Exit <Rope Cover>	

3. SPECIFICATIONS

3.1 BISOMAC210 PNEUMATIC TRACTION HOIST

ALL BISOMAC210 PNEUMATIC TRACTION HOISTS:	
Noise	64 dB
Rated Speed	Up to 35 ft/min (10.6 m/min)
Hoist Self Weight	108 lb (49 kg)
Weight including safety devices	119 lbs (54 kg)
Dimension w/safety devices	29.5 in. (750 mm high) x 12.4 in. (315 mm width) x 17.9 in. (455 mm depth)
Dimension w/o safety devices	11.5 in. (292 mm high) x 12.4 in. (315 mm width) x 15.5 in. (394 mm depth)
Motor Power	4 hp
Safety Features	Spring Engaged Brake
	Controlled Descent Device
	Overspeed Detection Device
MAINTENANCE SPECIFICATIONS:	
Maintain approximately every 100 hours or no longer than once a year. See Maintenance Manual for instructions on maintaining. (this may differ from conditions of use at work sites, refer to the BISOMAC210 Electric Operator's Manual Section 4: Work Environment)	

3.1.A BISOMAC210-1000A PNEUMATIC TRACTION HOIST

Model:	BISOMAC210-1000A	
Rated Load	750 lb (340 kg)	1,000 lb (450 kg)
Max. Air Pressure (U.S.A.)	65 psi (4.5 bar)	90 psi (6.2 bar)
Max. Air Pressure (CAN)	35 psi (2.4 bar)	45 psi (3.1 bar)
Motor Air Consumption	Avg. 35 cfm (Max 70 cfm)	
Wire Rope Diameter	5/16 inch (8 mm)	

3.1.B BISOMAC210-1508A PNEUMATIC TRACTION HOIST

Model:	BISOMAC210-1508A		
Rated Load	750 lb (340 kg)	1,000 lb (450 kg)	1,500 lb (680 kg)
Max. Air Pressure (U.S.A.)	65 psi (4.5 bar)	90 psi (6.2 bar)	110 psi (7.6 bar)
Motor Air Consumption	Avg. 40 cfm (Max 70 cfm)		
Wire Rope Diameter	5/16 inch (8 mm)		

3.1.C BISOMAC210-1500A PNEUMATIC TRACTION HOIST

Model:	BISOMAC210-1500A		
Rated Load	750 lb (340 kg)	1,000 lb (450 kg)	1,500 lb (680 kg)
Max. Air Pressure (U.S.A.)	65 psi (4.5 bar)	90 psi (6.2 bar)	110 psi (7.6 bar)
Max. Air Pressure (CAN)	35 psi (2.4 bar)	45 psi (3.1 bar)	65 psi (4.5 bar)
Motor Air Consumption	Avg. 40 cfm (Max 70 cfm)		
Wire Rope Diameter	3/8 inch (9 mm)		

3.2 OVERSPEED DETECTION DEVICE

Rated Load	750 lb (340 kg), 1000 lb (450 kg) or 1500 lb (680 kg)
Activation Speed	98.4 ft/min (30 m/min)
Dimension	10 in. (253 mm high) x 4.7 in. (120 mm width) x 4 in. (103 mm depth)
Weight	11 lb (5 kg)
Control Feature	NO descending while this device is activated.

3.3 FILTER, REGULATOR AND LUBRICATOR

Max Inlet Pressure	250 psi
Temperature Range	23 - 175 F
Dimension	14 in. (355 mm high) x 12 in. (305 mm width) x 5 in. (127 mm depth)
Drain Type	Manual Drain (Auto Drain optional)
Lubricator Bowl Capacity	3.2 oz
Lubrication Type	Class 1 #10 Air Tool Oil
Lubrication Frequency	5-7 drops per minute

4. FUNCTION AND DESCRIPTION OF EACH COMPONENT

4.1 BISOMAC210 TRACTION HOIST

[Front Isometric View]

- A: Pneumatic Motor
- B: Gear Box
- C: "DOWN" Exhaust
- D: Manifold
- E: Valve
- F: Operation Lever Arm
- G: Shackle for Transportation
- H: Suspension Wire Rope Inlet
- I: Air Brake Assembly
- J: Brake Plug
- K: Carrying Grip
- L: Guard Plate for Brake Line
- M: Emergency Descent Lever
- N: Lever Stopper
- O: Fluid Refill Hole
- P: Air Hose Twist Coupler
- Q: Serial Number

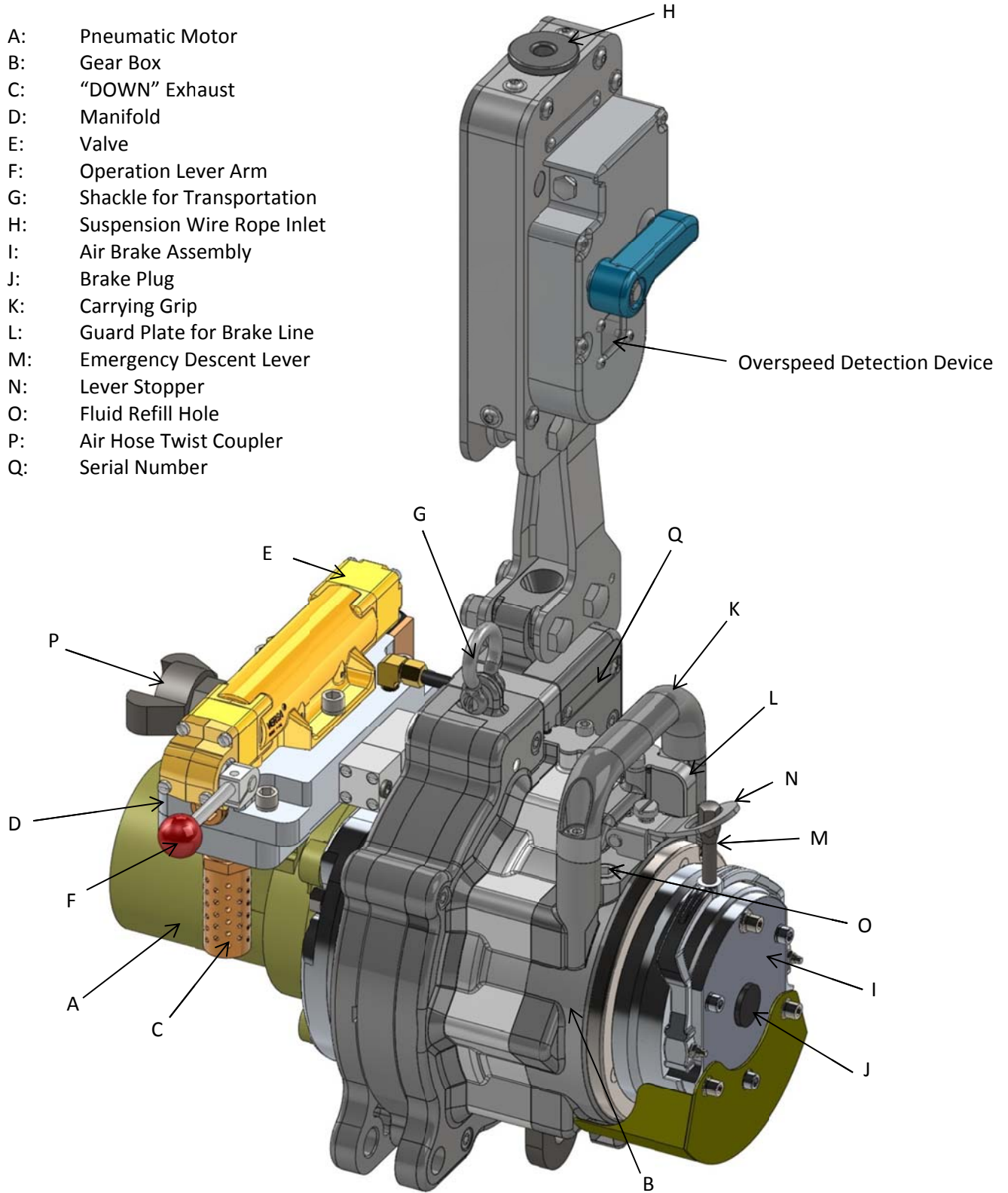

[Back Isometric View]

- R: "UP" Exhaust #1
- S: "UP" Exhaust #2
- T: Fluid Drain Hole
- U: Oil Level Gage

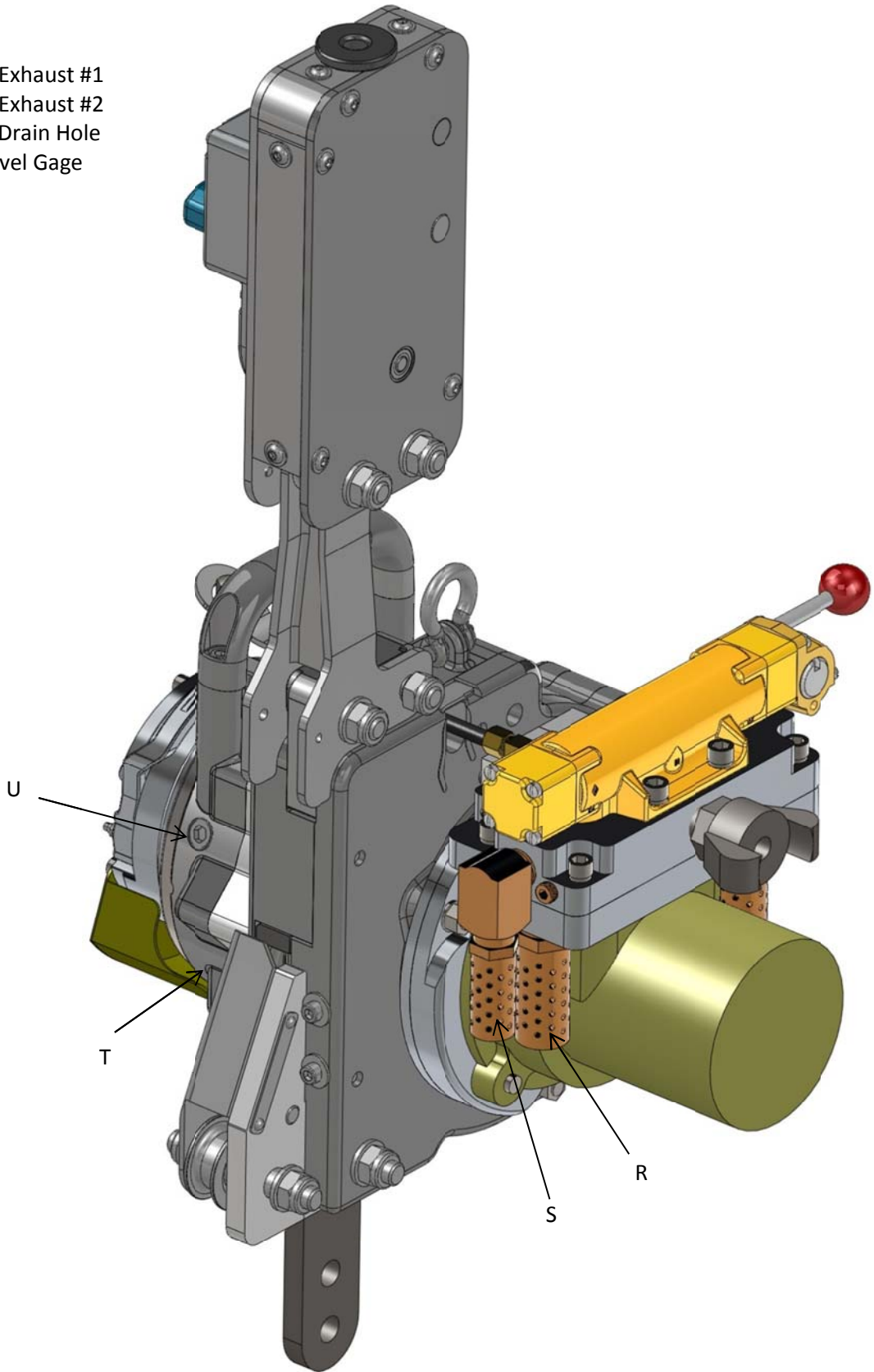

	FUNCTION	DESCRIPTION
A	Pneumatic Motor	BISOMAC210 operates by air pressure through gear drive.
B	Gear Box	Gear Box of BISOMAC210.
C	"DOWN" Exhaust	3/4" NPT exhaust muffler to reduce noise during descent.
D	Manifold	Directs air pressure to motor to provide "UP" or "DOWN" travel and brake.
E	Valve	Directs air pressure to manifold to provide "UP" or "DOWN" travel.
F	Operation Lever Arm	Controls the vertical motion of the BISOMAC210.
G	Shackle for Transportation	Only use for transportation of the BISOMAC210. Max lifting load is 165 lbs (75 kg).
H	Suspension Wire Rope Inlet	For inserting main suspension wire rope.
I	Pneumatic Brake Assembly	Pneumatic Brake Assembly is released when the Operation Button is Operation Lever Arm is rotated. The BISOMAC210 stops when the Operation Lever Arm is released (and returns to its center position) or the air pressure is lost.
J	Brake Plug	Provides access to Gear Box axle.
K	Carrying Grip	Carrying Grip for the BISOMAC210.
L	Guard Plate for Brake Line	Protects Brake Line from damage.
M	Emergency Descent Lever	This allows the platform to be lowered at regular speed when air pressure to the BISOMAC210 is lost.
N	Lever Stopper	Prevents misoperation & malfunction of Emergency Descent Lever.
O	Fluid Refill Hole	Use when replacement of oil.
P	Air Hose Twist Coupler	Quick connection from air source to manifold.
Q	Serial Number	BISOMAC210 Serial Number.
R	"UP" Exhaust #1	3/4" NPT exhaust muffler to reduce noise during ascent.
S	"UP" Exhaust #2	1/2" NPT exhaust muffler to reduce noise during ascent.
T	Fluid Drain Hole	Use when replacing oil.
U	Oil Level Gage	Use when checking and/or replacing oil.
V	Inlet for Pendant (on Valve)*	Directs air pressure to manifold to provide "UP" or "DOWN" travel via pendant.
W	Inlet for Pendant (on Manifold)**	Provides air pressure to pendant of "UP" or "DOWN" operation.

* : Inlets for Pendant (on Valve) is an optional feature. See Pendant Instructions.

** : Inlet for Pendant (on Manifold) is an optional feature. See Pendant Instructions.

4.2 FILTER, REGULATOR AND LUBRICATOR



	FUNCTION	DESCRIPTION
A	Filter	Filters compressed air and drains excess moisture.
B	Regulator Knob	Regulates air pressure from compressor to hoist.
C	Regulator Display	Displays air pressure going out.
D	Lubricator	Lubricates air with oil.
E	Air Pressure "IN"	Air pressure goes into "IN" port from compressor.
F	Air Pressure "OUT"	Air pressure goes out "OUT" port to hoist.

4.3 FILTER, REGULATOR AND LUBRICATOR ASSEMBLY

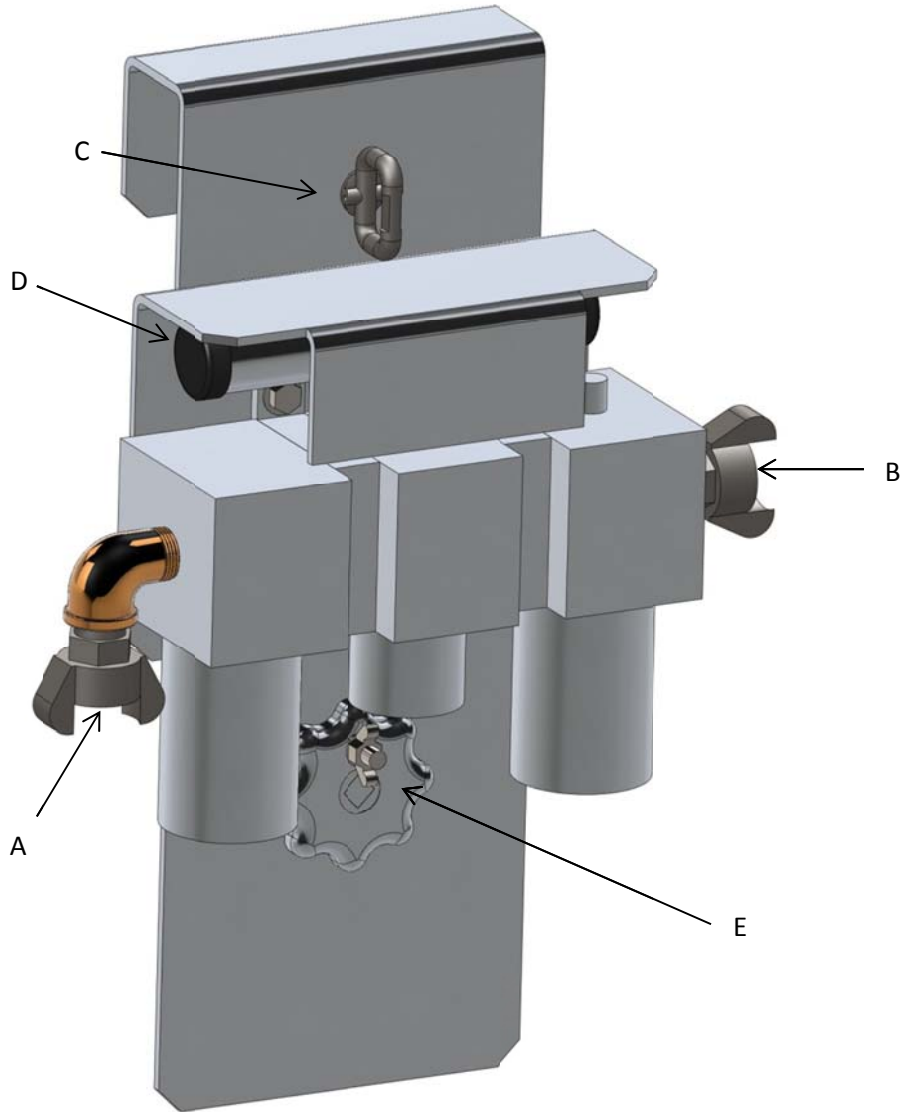

	FUNCTION	DESCRIPTION
A	Air Pressure "IN"	Air hose (from compressor) connects to Air Hose Twist Coupler.
B	Air Pressure "OUT"	Air hose connects Filter, Regulator and Lubricator Assembly to Air Hoist via Air Hose Twist Coupler.
C	Guardrail Mount with Locking Pin	Allows Filter, Regulator and Lubricator Assembly to rest on Top Guardrail and secured into position.
D	Operators Manual Tube	Location to stow Operator's Manual.
E	Emergency Ascent Wheel	Allows operator to raise platform (turn motor shaft) in the event of a loss of air pressure.

5. SET UP / INSTALLATION

5.1 HOIST ASSEMBLY (Installation of Safety Devices and Stirrup Strap to the BISOMAC210):

- Install Overspeed Detection Device to the Hoist with the provided hardware (Special Bolts, M12 Washers and M12 Nylon Nuts). Tighten the bolts using a Torque Wrench to 76 N • m (770 kgf • cm).
- Install Stirrup Strap to the Hoist with the provided hardware (Special Bolt, M12 Washer and M12 Nylon Nut). Tighten the bolts using a Torque Wrench to 76 N • m (770 kgf • cm).

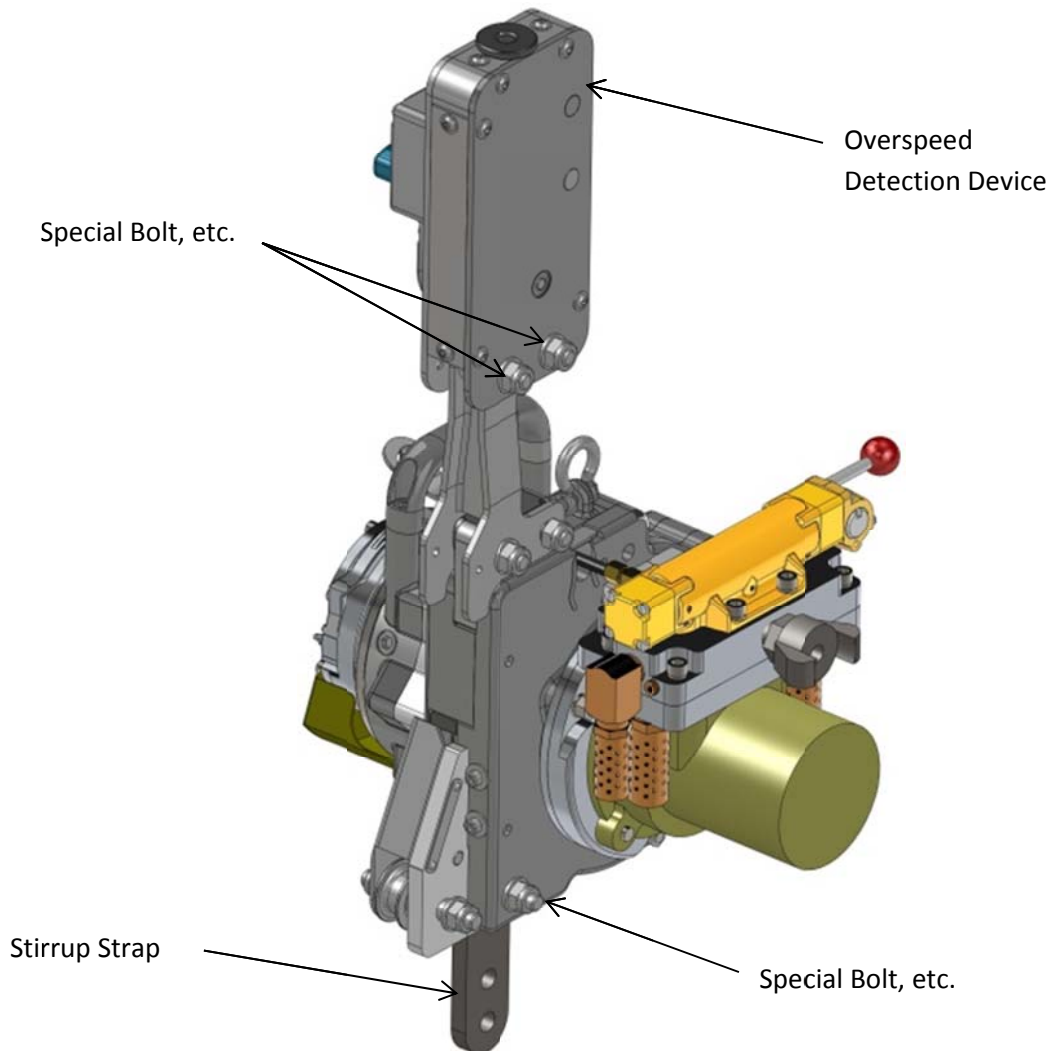

5.2 CONNECTION OF AIR SUPPLY (Connect Filter, Regulator and Lubricator Assembly to Air Supply and BISOMAC210):

- Connect Filter, Regulator and Lubricator Assembly to the 3/4" Air Hose via Twist Couplers (lock into position with pin or wire).
- Connect the other end of the Air Hose to the BISOMAC210 via Twist Couplers (lock into position with pin or wire).
- Verify Lubricator is filled with oil.
- Verify that all connections are secured and locked into position via locking pins.
- Slowly pressurize air lines by turning on compressor and SLOWLY opening valve.
- Dial Regulator to required pressure. Dial the center position until air pressure raises/lowers to the required pressure (may need to rotate Operation Lever Arm on hoist to reduce pressure). **WARNING: DO NOT EXCEED 110 psi.**
- Press filter base to relieve any water in holding container (periodically do this during use). If auto drain filter is being used, this is not required.

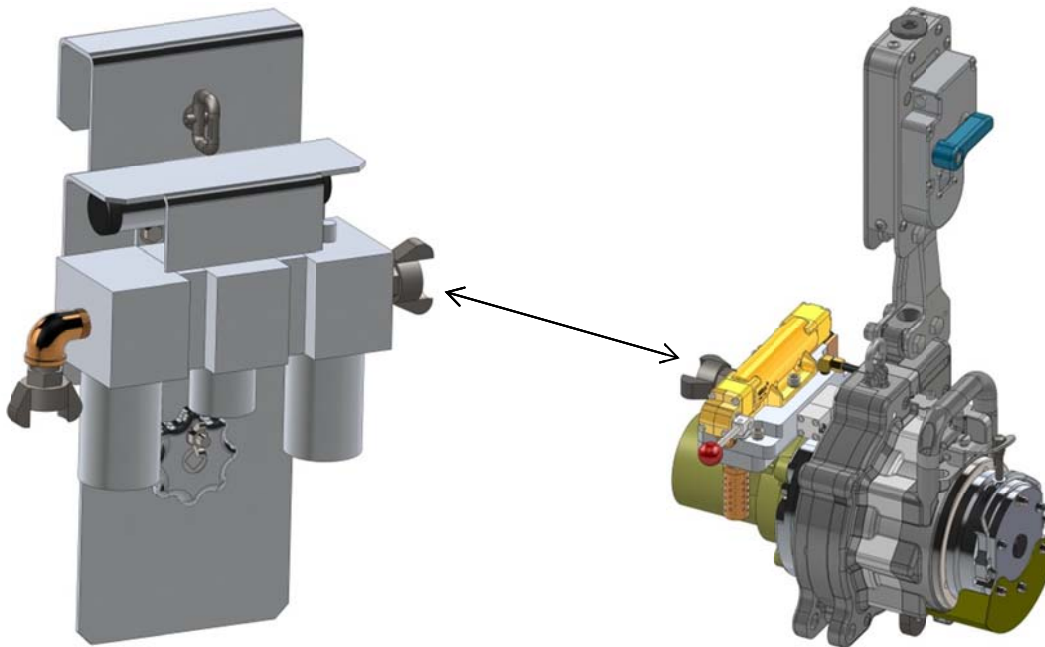

5.3 INSTALLING THE BISOMAC210 ONTO THE STIRRUP:

1. Rotate the Operation Lever Arm so that it sticks directly out.
2. Verify that rigging is assembled correctly and meets all of the required federal, state, provincial and local safety regulations.
3. Verify that the entire suspended scaffold system and any component of it is assembled correctly and meets all of the required federal, state, provincial and local safety regulations.
4. Verify that each suspension wire rope is positioned with the correct spacing (distance between suspension points is equal to the distance between hoists/stirrups).
5. Raise the hoist by rotating the Operation Lever Arm in the "UP" direction (or by lifting the BISOMAC210) until the holes in the stirrup strap line up with the holes in the stirrup.
6. Attach the BISOMAC210 to the stirrup with the provided hardware (2 Fix Bolts, 4 Washers and Nylon Nuts). Position of the ROPE END should be outside of the platform. Tighten the bolts using a Torque Wrench to 76 N • m (770 kgf • cm).
7. To avoid run off the suspension wire rope from the BISOMAC210, make the loop on the end of the suspension wire rope and fix it using the clamp as shown in the illustration below.

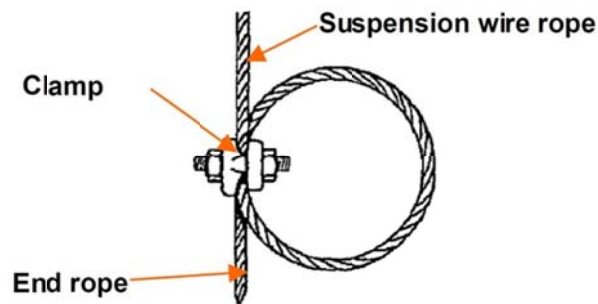

5.4 CONFIRMING OPERATION OF OVERSPEED DETECTION DEVICE:

Perform the following procedure on the GROUND to make sure the Overspeed Detection Device is operating normally.

1. Insert about 12 in. (30 cm) of wire rope into the Overspeed Detection Device inlet.
2. Pull up the wire rope quickly.
The Reset Lever turns anticlockwise and the Overspeed Detection Device grabs the wire rope.
3. Make sure that the wire rope is engaged.
4. Push down the Reset Lever to reset.

Perform the following procedures on the PLATFORM to make sure the Overspeed Detection Device holds loads normally.

1. Raise the platform about 20 in. (50 cm) off the ground.
2. Press the Manual Trip Button to activate the Overspeed Detection Device. The Reset Lever turns anticlockwise and the Overspeed Detection Device grabs the wire rope.
3. Release the Pneumatic Brake by pulling the Emergency Descent Lever to lower the platform.
4. The Overspeed Detection Device engages the wire rope and the platform stops descending.
5. Rotate the Operation Lever Arm in the "DOWN" direction to confirm the platform will not descent. (**NOTE: Wire rope will exit between the hoist and the Overspeed Detection Device. DO NOT allow this wire rope to kink.**)
6. Confirm that the Overspeed Detection Device is supporting the full weight of the platform.
7. Rotate the Operation Lever Arm in the "UP" direction and verify that the wire rope between the hoist and the Overspeed Detection Device is NOT kinked.
8. After the platform raises a little, press down the Reset Lever to reset the Overspeed Detection Device.
9. Rotate the Operation Lever Arm in the "UP" direction to raise the platform and confirm that the Governor is rotating.
10. Perform the same procedure to ALL Overspeed Detection Device on the platform.

If the Overspeed Detection Device does not engage the wire rope, contact the BISOMAC210 local distributor and replace it with a properly functioning Overspeed Detection Device.

WARNING: If the Overspeed Detection Device engages during downward operation of the BISOMAC210, the wire rope will exit between the hoist and the Overspeed Detection Device. DO NOT allow this wire rope to kink. If the wire rope does kink, unkink the wire rope and slowly rotate the Operation Lever Arm in the "UP" direction to guide the unkinked wire rope back into the BISOMAC210.

6. OPERATING INSTRUCTIONS

This section describes the procedure to safely operate the BISOMAC210. Before operating, read and understand this section which describes the operation of the BISOMAC210 and the safety devices.

6.1 REEVE WIRE ROPE

- Verify that all connections are secured and locked into position via locking pins.
- Slowly pressurize air lines by turning on compressor and SLOWLY opening valve.
- Dial Regulator to required pressure (may need to rotate Operation Lever Arm on hoist to reduce pressure).
- Insert the bullet end of the wire rope approximately 16 in. (40 cm) into the suspension wire rope inlet of the BISOMAC210.
- Press the Operation Lever Arm in the "UP" direction while maintaining downward pressure on the wire rope until self-reeving starts.
- Make sure the wire rope can freely exit the BISOMAC210 and is not blocked by any parts.

6.2 HOIST OPERATION

- Rotate the Operation Lever Arm in the "UP" direction to ascend (raise) the platform
- Rotate the Operation Lever Arm in the "DOWN" direction to descend (lower) the platform

6.3 EMERGENCY DESCENT LEVER OPERATION

- In the event of a loss of air pressure, the BISOMAC210 may be lowered using the Emergency Descent Lever.
- If you desire to lower the BISOMAC210:
 - 1) Loosen the Screw and raise the Lever Stopper.
 - 2) Release the Pneumatic Brake by gently pulling the Emergency Descent Lever as far as it will go toward the arrow as shown. The BISOMAC210 will safely descend.
 - 3) Release hand from the Emergency Descent Lever to stop the BISOMAC210.

NOTE: DO not apply excess load to the Emergency Descent Lever. The handle/pin will break if approximately 220 lbs power is applied and you will not be able to descend in an emergency condition. Refer to Maintenance manual to repair the handle/pin.

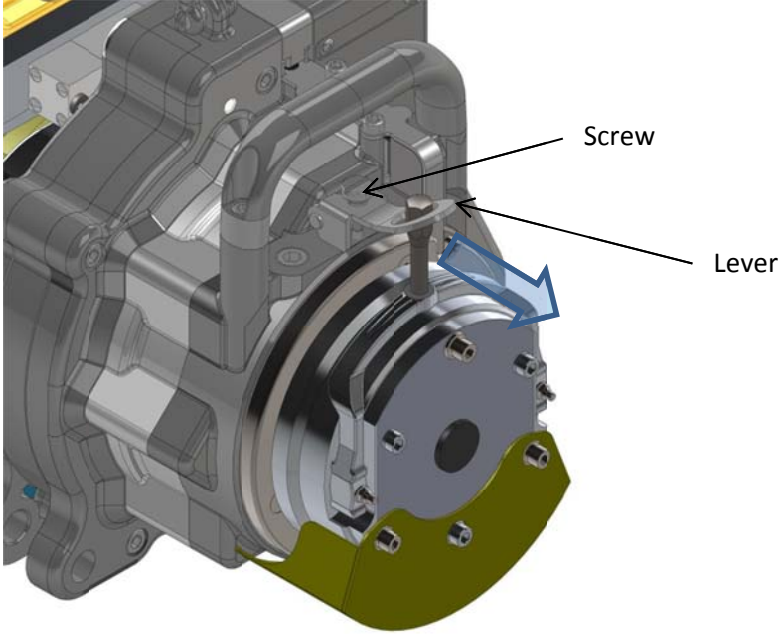

6.4 EMERGENCY ASCENT WHEEL OPERATION

In the rare event that the Overspeed Detection Device engages onto the wire rope when there is a loss of air pressure and the operator is using the Controlled Descent Device, the operator may raise the platform a few inches using the Emergency Ascent Wheel. This is located below the Filter, Regulator and Lubricator.

1. Remove plug from brake assembly
2. Remove Emergency Ascent Wheel from Filter, Regulator and Lubricator Assembly
3. Insert square end of Emergency Ascent Wheel into brake assembly and engage onto motor shaft
4. Apply pressure to Emergency Ascent Wheel and pull (release) brake handle
WARNING: DO NOT release brake handle until pressure is on the Emergency Ascent Wheel.
5. Rotate Emergency Ascent Wheel (while releasing brake)
6. Release brake and stop rotating
WARNING: DO NOT release pressure on Emergency Ascent Wheel until brake is engaged.
7. Continue steps 4-6 until the overspeed device can be reset

7. PERIODIC INSPECTIONS

In addition to the periodic inspections described in the BISOMAC210 Electric Traction Hoist Operator's Manual (Section #8), below are several other inspections to be performed by certified personnel.

	Frequency	DESCRIPTION
1	Daily	Verify oil is in lubricator and drain moisture from filter
2	Weekly	Inspect Filter
3	Monthly	Inspect air lines for cracks
		Inspect quick connect fittings are secure to air lines
		Inspect "UP" and "DOWN" exhausts as they may need to be cleaned/replaced for better efficiency.

8. TROUBLESHOOTING AT JOB SITE

(Problem from Mishandling)

The following information is intended to help identify faults that can occur and recommended correction(s).

WARNING:

If the problems (case 1 – case 8) cannot be solved by performing the corrective measures below, replace the hoist or contact local authorized BISOMAC210 distributor. All repairs and solution of these problems must be performed by trained and certified service personnel, otherwise, this may cause the platform to fall or tilt, and consequently operators or objects might fall, resulting in serious injury, death or damage to operators or passers-by.

Problem	Possible Causes	Solution
CASE (1): Push Lever Arm "UP" or "DOWN", but BISOMAC210 will not Operate	Main Air line is not connected or not on	Confirm that the main air line is connected to the Filter
		Confirm that the air line is connecting the Lubricator to the Hoist
		Confirm that the main air source is turned on
	Brake Assembly is not releasing	Air fittings have been removed from the Manifold or from the Brake Assembly
		Brake air line has been punctured. (Replace air line)
		Manually release brake by pulling Emergency Descent Lever to remove any potential build up
Problem	Possible Causes	Solution
CASE (2): Hoist will Descend, but BISOMAC210 will not Ascend	Regulator is not at required pressure	Confirm that the Regulator is registering the required pressure (Rotate knob until air pressure raises to the required pressure)
	Weight is exceeded	Verify platform weight + material + personnel does not exceed hoist load capacity
	Air pressure is too low	Supply air pressure is within allowable pressure of BISOMAC210
	Air line is too long or size is too small	Shorten air line or use larger size
Problem	Possible Causes	Solution
CASE (3): Hoist will Ascend, but BISOMAC210 will not Descend	Overspeed Detection Device may be activated	Raise platform and reset Overspeed Detection Device
Problem	Possible Causes	Solution
CASE (4): Hoist motor runs, but Hoist will not self-reeve	Inadequate bullet on the wire rope	Make sure the proper wire rope is used. (See BISOMAC Electric Traction Hoist Operator's Manual Section 7.2.2)
	Wire rope is worn or damaged	Stop operation of the BISOMAC210 immediately and replace wire rope
	The exit of wire rope is blocked	Remove obstruction which caused blockage
Problem	Possible Causes	Solution
CASE (5): Hoist self-reeves, but will not lift platform	Regulator is not at required pressure	Confirm that the Regulator is registering the required pressure (Rotate knob until air pressure raises to the required pressure)
	Weight is exceeded	Verify platform weight + material + personnel does not exceed hoist load capacity
	Air pressure is too low	Supply air pressure is within allowable pressure of BISOMAC210
	Air line is too long or size is too small	Shorten air line or use larger size
	Inadequate bullet on the wire rope	Make sure the proper wire rope is used. (See BISOMAC Electric Traction Hoist Operator's Manual Section 7.2.2)
	Wire rope is worn or damaged	Stop operation of the BISOMAC210 immediately and replace wire rope

Problem	Possible Causes	Solution
CASE (6): BISOMAC210 ascending speed is too slow	Regulator is not at required pressure	Confirm that the Regulator is registering the required pressure (Rotate knob until air pressure raises to the required pressure)
	Weight is exceeded	Verify platform weight + material + personnel does not exceed hoist load capacity
	Air pressure is too low	Supply air pressure is within allowable pressure of BISOMAC210
	"UP" Exhausts are clogged	Replace or clean "UP" Exhausts
	Air line is too long or size is too small	Shorten air line or use larger size
	Wire rope is worn or damaged	Stop operation of the BISOMAC210 immediately and replace wire rope
Problem	Possible Causes	Solution
CASE (7): BISOMAC210 makes unusual noise	Each device's bolts and nuts are loosened	Check them and tighten them properly
	"UP" Exhausts are clogged	Replace or clean "UP" Exhausts
	"DOWN" Exhaust is clogged	Replace or clean "DOWN" Exhaust
Problem	Possible Causes	Solution
CASE (8): BISOMAC210 is too hot	Frequent use of BISOMAC210	Strict observance of BISOMAC210 operation hours (See BISOMAC Electric Traction Hoist Operator's Manual Section 6)
	Brake Assembly is not releasing fully	Air fittings have loosened from the Manifold or from the Brake Assembly and are leaking
		Brake air line has been punctured or kinked. (Replace air line)
		Manually release brake by pulling Emergency Descent Lever to remove any potential build up